



WIŚNIEWSKI



Garage doors
SECTIONAL



GARAGE DOORS **SECTIONAL**

GENERAL OVERVIEW	4 - 23
---------------------	--------

UNIPRO	24 - 27
--------	---------

UNITHERM	28 - 33
----------	---------

PRIME	34 - 43
-------	---------

RENOVATION SOLUTIONS	44 - 51
-------------------------	---------

AVAILABLE VERSIONS	52 - 81
-----------------------	---------

INSPIRATION	82 - 100
-------------	----------

TECHNICAL INFORMATION	101 - 128
--------------------------	-----------



www.wisniowski.eu



Why **WIŚNIEWSKI**?

For the last three decades, we have been working in accordance with the idea of the founder of the WIŚNIEWSKI brand, Andrzej Wiśniowski, who made it his goal to create innovative products addressing all of our customers' needs.

We want your home to be secure and comfortable. Taking advantage of our 30 years of experience in the production of garage doors, gates, windows, doors, and fences, we offer our customers top quality products. We know what a modern home needs and what challenges the household may face.

Currently, our production hall spanning 270,000 square metres manufactures thousands of garage doors, gates, windows, doors, and fences every day. At the same time, we are also able to customize the products to meet our customers' requirements.

Everyone has different needs and expectations, which is why when manufacturing our products, we focus on listening to what you have to say. Meet the WIŚNIEWSKI brand – enter the world of comfort and security.





WIŚNIEWSKI. Gates, windows, doors, fences.



Welcome to the world of **WIŚNIOWSKI** garage doors

Choose one of our sectional, up and over, roller or double leaf garage door solutions.

This **diversity** is our response to the requirements of our customers. Let us surprise you with the multitude of options.

We present to you the **classy, safe, and functional** sectional garage doors by WIŚNIOWSKI.



Choose the right garage door **for you**

PANEL
INNOVO
60 mm



PRIME. The new generation
of sectional garage doors.

LUXURY CLASS

Sectional garage doors by WIŚNIOWSKI provide a wide variety of possibilities for closing off your garage. Three classes of sectional garage doors make up a unique offer which lets you select the solution that is right for you. Aside from their function, the **PRIME, UniTherm, and UniPro** garage doors meet the highest standards of comfort and safety. They feature innovative design solutions enabling our sectional doors to be used in all environments, for both new and renovated buildings. They also reflect the trends in modern design.

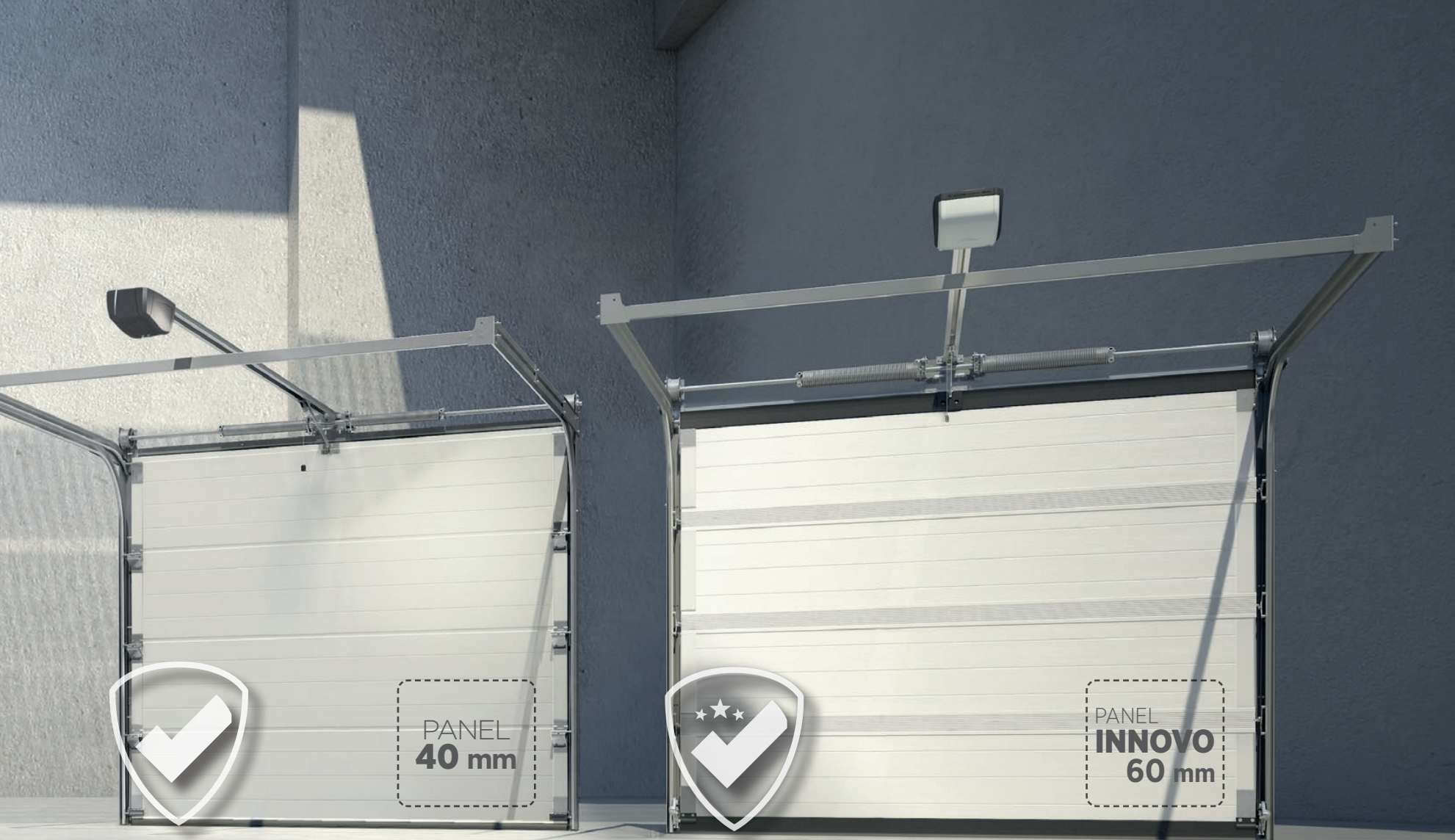

PANEL
40 mm

STANDARD CLASS

UniPro.

Timeless versatility.



PANEL
INNOVO
60 mm

PREMIUM CLASS

UniTherm.

Efficient thermal insulation.

AVAILABLE GARAGE DOOR DESIGNS



UniPro

- Torsion spring system designed for **25,000 cycles**
- **Galvanized** construction
- Panel: **40 mm**
- Panel heat transfer coefficient **Up=0.48 W/m²K⁽¹⁾**
- Rollers **with bearings**

UniTherm

- Torsion spring system designed for **25,000 cycles**
- **Galvanized** construction
- Panel: **INNOVO 60 mm**
- Panel heat transfer coefficient **Up=0.33 W/m²K⁽¹⁾**
- **Double** rollers **with bearings**
- **Flexible** panel **joint covers**
- **Double** bottom **gasket**

PRIME

- Torsion spring system designed for **25,000 cycles**
- **Galvanized and painted** construction
- Panel: **INNOVO 60 mm**
- Panel heat transfer coefficient **Up=0.33 W/m²K⁽¹⁾**
- **Double** rollers with bearings
- **Flexible** panel **joint covers**
- **Double** bottom **gasket**
- **Protection system** for mechanical elements
- **Modern automatic operating units** with high standard accessories

⁽¹⁾ - U factors of the door depending on the dimensions are specified in the table on page 99. The factors are provided for doors without glazing, wicket doors, ventilation grilles, aluminium panels, and additional thermal gaskets.



Low ribs



V ribs



High ribs



No ribs



Caisson ribs

UniPro

Woodgrain	RAL 7016, RAL 8014, RAL 9006, RAL 9016, other RAL*, Golden Oak, Walnut	—	RAL 7016, RAL 8014, RAL 9016, other RAL*, Golden Oak, Walnut	RAL 7016, RAL 8014, RAL 9016, other RAL*, Golden Oak, Walnut	RAL 9016, other RAL* Golden Oak
Smoothgrain	—	—	Golden Oak, Walnut 41 film coatings	Golden Oak, Walnut 41 film coatings	—
Sandgrain	—	—	Anthracite	Anthracite	—
Silkline	RAL 7016, other RAL*	RAL 7016, RAL 9006, other RAL*	RAL 7016, RAL 9005, RAL 9016, other RAL*	RAL 7016, RAL 9005, RAL 9016, other RAL*	—
Home Inclusive 2.0	16 colors	—	16 colors	16 colors	—

UniTherm

Smoothgrain	—	—	Golden Oak, Walnut	Golden Oak, Walnut 41 film coatings	—
Sandgrain	—	—	Anthracite	Anthracite	—
Silkline	—	—	RAL 7016, RAL 9016, other RAL*	RAL 7016, RAL 9016, other RAL*	—
Home Inclusive 2.0	—	—	16 colors	16 colors	—

PRIME

Smoothgrain	—	—	Golden Oak, Walnut	Golden Oak, Walnut 41 film coatings	—
Sandgrain	—	—	Anthracite	Anthracite	—
Silkline	—	—	RAL 7016, RAL 9016, other RAL*	RAL 7016, RAL 9016, other RAL*	—
Home Inclusive 2.0	—	—	16 colors	16 colors	—

* The garage door leaf can be painted in RAL colours – only for garage doors with woodgrain and silkline structure (excluding pearlescent, reflective, and metallic finish, as well as special colours)

Form and **function**

Sectional garage doors by WIŚNIOWSKI are manufactured using two types of panels:

- 40 mm panel for UniPro garage doors,
- INNOVO 60 mm panel for PRIME and UniTherm garage doors.

All our panels are manufactured in the WIŚNIOWSKI facility using state-of-the-art technological lines which ensure high quality and repeatability at each stage of the manufacturing process. High technical parameters and reliable corrosion protection are obtained thanks to the use of high grade, galvanized steel with paint or film coating. The stiff polyurethane foam core ensures optimum strength for the panels and improves their thermal insulation. Special solutions, such as the 5-layer sheet bending system ensures stable fastening of elements, which further increases the strength of our design.

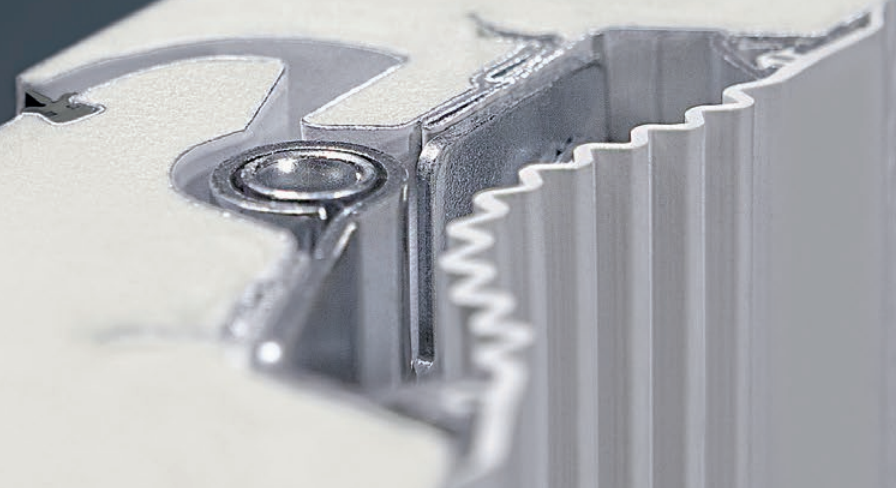

PANEL
40 mm

PANEL
INNOVO
60 mm

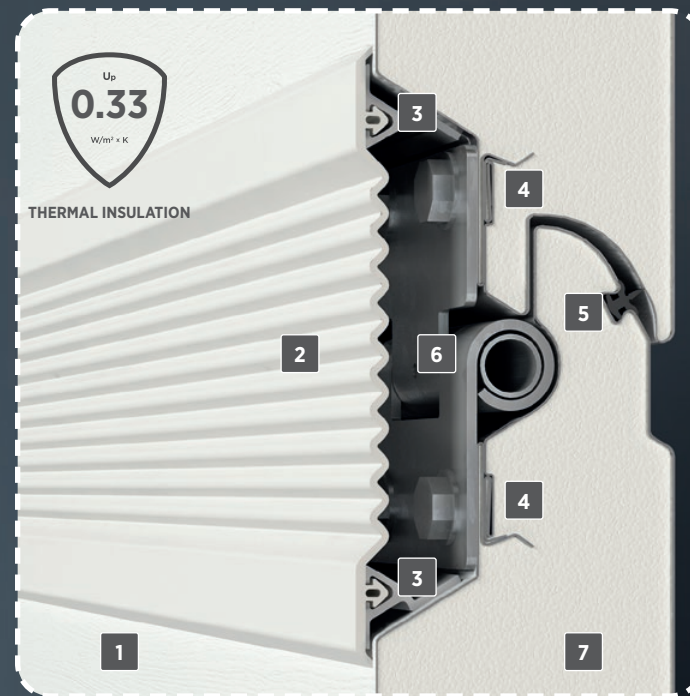

UniPro garage door

PRIME, UniTherm garage door

1. Closed panel construction.
2. Flexible panel joint cover.
3. Aluminium profile for fastening flexible covers.
4. Five sheet layers at the hinges.
5. Panel joint seal.
6. Concealed hinge.
7. Polyurethane foam.

Revolutionary **thermal insulation**

The PRIME sectional garage doors are all about thermal insulation, which makes them a recommended choice for energy efficient and even passive buildings. PRIME is the answer whenever energy efficiency is a priority.

Thanks to the panels with thermal insulation and our sealing systems, we managed to eliminate heat loss in the most affected areas of the leaf to ensure parameters that let the sectional garage doors keep an optimum temperature inside your garage.

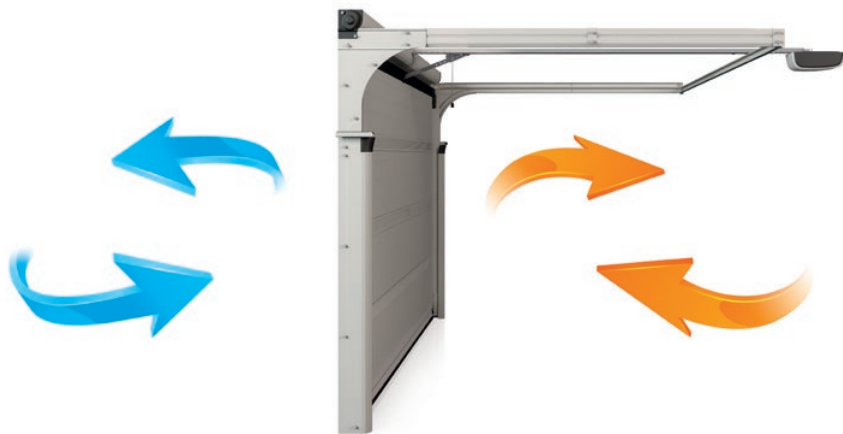

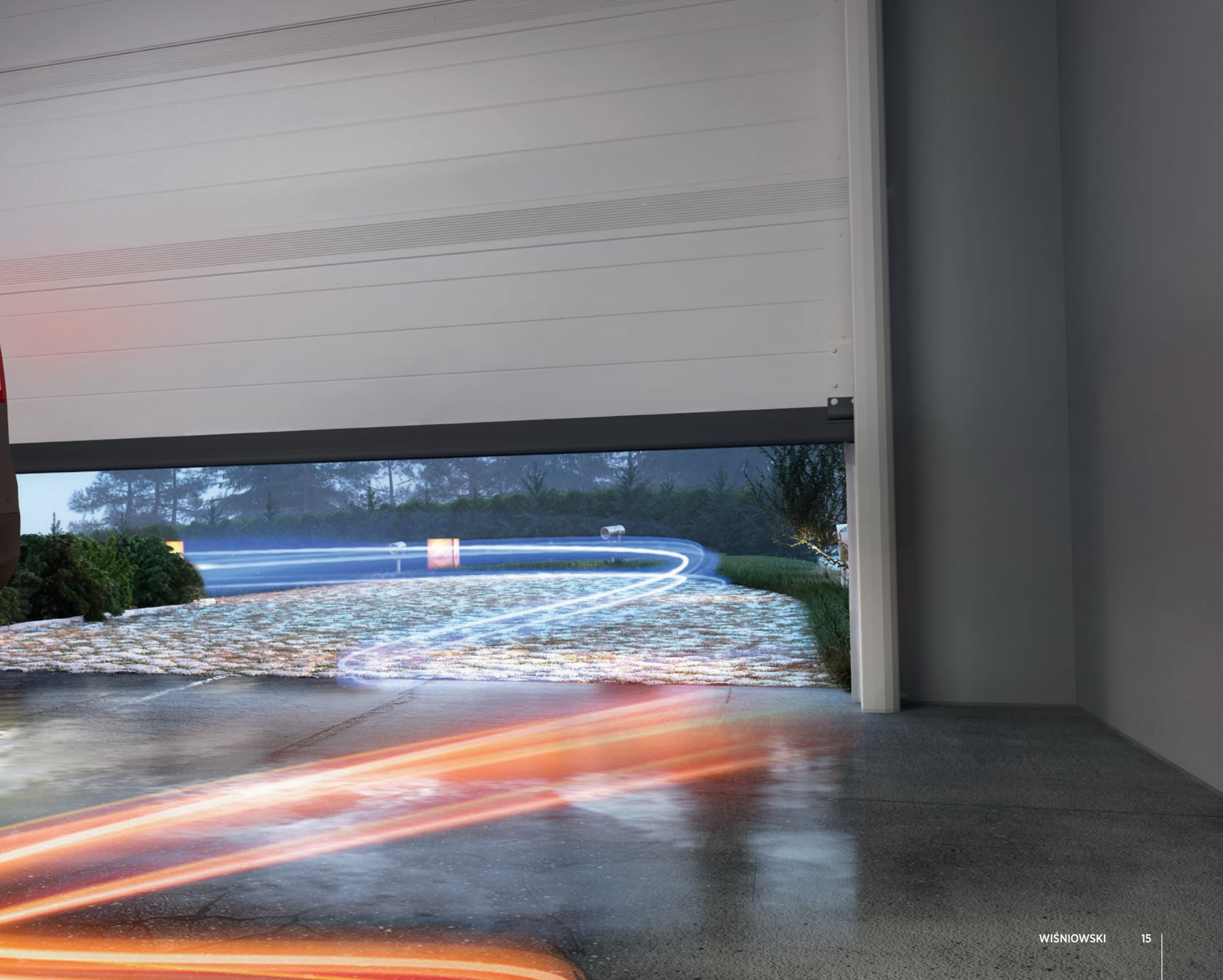

Thinking about your comfort **and safety**

Protection systems used in the WIŚNIEWSKI sectional garage doors are designed to meet all the current requirements.

However, the safety and comfort of the user, as well as garage access protection are the two most important aspects.

Our garage doors meet the stringiest safety standards, which is certified by the Declaration of Performance and the CE marking.

We managed to ensure high safety standards thanks to the use of a number of technological solutions, such as special panel shape, safety brakes, an integrated spring break safety system, and rollers with bearings.



SAFETY





Functionality **and** **reliability that lasts**

We insist on implementing solutions that extend the life of our garage doors already at the design stage. Our TÜV SÜD certificate guarantees that all the processes are strictly supervised along each stage, from the purchase of raw materials, through design and manufacture, up to the final product and customer support. It is a promise of the highest quality, safety, and comfort at each stage of use. Our customers can take advantage of an extension of the standard warranty for up to 5 or 3 years by signing up for the EXTENDED CARE programme that covers automatic garage doors factory configured with the METRO or MOTO drive unit. Would you like to find out more about controlling your home features using a smartphone? The smartCONNECTED technology brings WIŚNIEWSKI automatic sectional garage doors to the next level of product development, tailoring them to the requirements of modern customers. On the one hand, it lets you control the devices with your smartphone, and on the other, it gives you full control and lets you stay in touch with your home from any place in the world.



The TÜV SÜD certificate confirms that our company operates in a systemic manner, which ensures that our processes are repeatable, our responsibility is transparent at each stage of meeting customers' demands, and that our processes are constantly being perfected.

5 years
**WARRANTY
EXTENDED CARE**

on automatic garage doors
with the **METRO** drive unit



3 years
**WARRANTY
EXTENDED CARE**

on automatic garage doors
with the **MOTO** drive unit



EXTENDED CARE warranty

Extend your standard warranty and enjoy the comfort and safety guaranteed by WIŚNIEWSKI products.



Live more comfortably with smartCONNECTED!

Manage your home and property from any place in the world. The smartCONNECTED system integrates WIŚNIEWSKI garage doors, windows, doors, and fences, and makes it possible to control them via an app. Set scenarios, open, close, check the status, and monitor – these are the features brought to you by the smartCONNECTED Box.



Remotely control
garage doors, gates,
windows, doors, and
roller shutters.



**Open garage doors
and gates**
without touching
your remote.



**Manage your
home** via a voice
assistant.

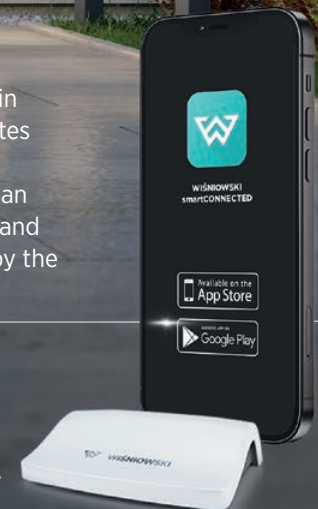

Anti-burglary safety kit RC2

Your home is your castle. We understand it very well and support you in building a safe space for you and your family. The anti-burglary safety kit provides an even better protection for your home.

Solutions designed by our engineers make the UniPro, UniTherm, and PRIME doors paired with the MOTO or METRO drive unit almost impossible to force open. The mechanism locks the door automatically and protects it from being opened by unauthorized persons.

The RC2 level burglary protection is confirmed by a certificate from the widely recognized IFT Institute, so you can rest assured that everything that is important to you is well protected.



**BURGLARY
PROTECTION**



Garage doors fitted with the RC2 burglary kit have a certificate issued by the IFT Rosenheim Institute (Germany) which confirms compliance with the DIN/TS 18194:2020 standard.



Prime



Prime garage door

UniTherm



Door: UniTherm SSp, UniTherm SSt

UniPro



Door: UniPro SSp, UniPro SSt, UniPro N80, UniPro SNP



New trends in **design**

Looking for classic models and timeless colours? Perhaps conventional solutions do not suit you? Regardless of what type of garage door you need, at WIŚNIEWSKI you will find the product that meets all your needs. For many years, WIŚNIEWSKI has been a pioneer in combining product functionality and aesthetics. The latest result of this approach is the PRIME Black Edition garage door. It is a unique garage door among those available on the market, featuring black internal finish. The elegant black with nearly unlimited leaf front colour and customization options makes it possible to create a design tailored to your needs and dreams.



DESIGN





WIŚNIEWSKI

WIŚNIEWSKI

UniPro. Always universal.

UniPro combines precision manufacturing and attention to detail with the vast range of designs, structures, colours, and decorative motifs. This lets you match the UniPro garage doors with both modern and traditional buildings. Thanks to the multitude of design solutions, the UniPro garage doors are used in new buildings, as well as in renovated buildings where other types of garage doors were used in the past. At the same time, they remain fully functional and maintain the parameters required to close the garage, which makes them one of the most universal solutions among garage doors.



**STANDARD
CLASS**





UniPro. Functionality and safety.

Safety is one of the most important factors in garage door use, and this is why apart from safe design, proper safeguards must be used to ensure that users are fully protected.



SAFETY



1

Special panel shape



2

Spring break safety device – a standard accessory for doors with a door surface area of $\geq 9 \text{ m}^2$

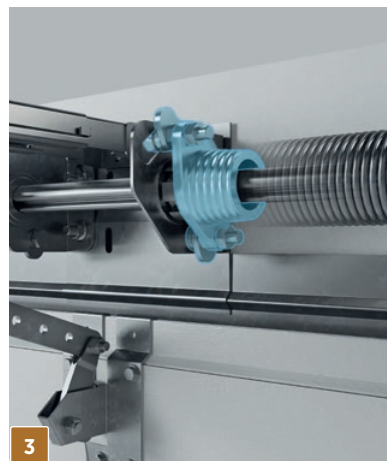

3

Integrated spring break safety device

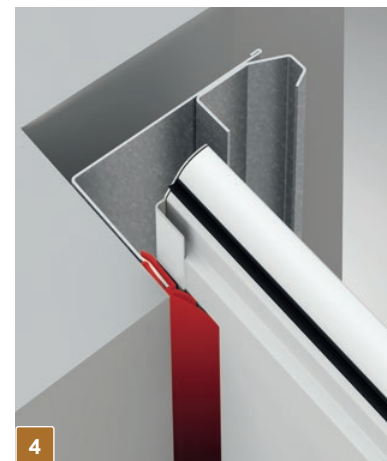

4

Double-lip circumferential seal



5

Overload safety device for automatic garage door



6

Photocells – option



7

Quiet guiding rollers (in doors with torsion springs)

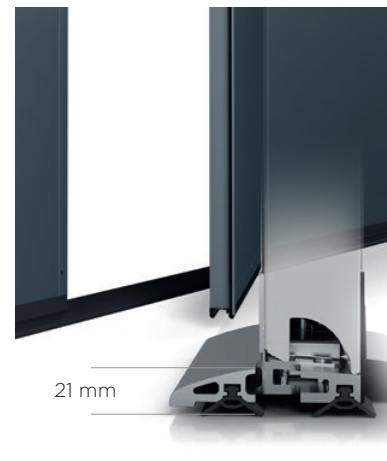

21 mm

Low threshold in wicket door
(21 mm high)

UniTherm.

New standards.

The UniTherm garage door has a high resistance to wind load and water ingress and low air permeability. These parameters not only increase the life of the garage door, but also let it maintain its aesthetic qualities for many years to come. This innovative design solution ensures durability and safety, and at the same time remains functional in everyday use.



**PREMIUM
STANDARD**





UniTherm.

Functionality and safety.

All the individual systems which make the garage door safe are interdependent and at the same time work in harmony with specific structural parts. For example, the inner covers at the panel joints and the safety brake. With a perfectly integrated drive system, UniTherm is a technological trendsetter which shows that quality and safety are inextricably linked here.



SAFETY



Flexible panel joint covers

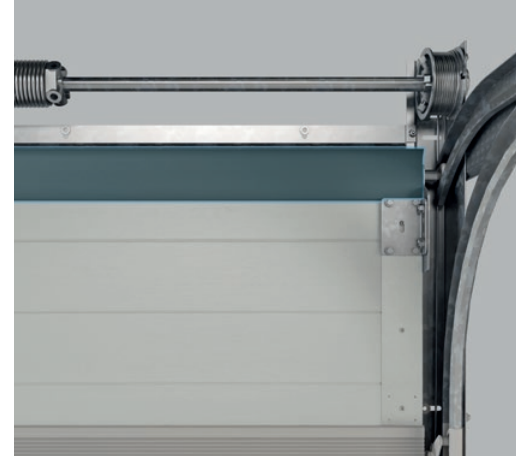

Additional inner cover – for garage doors with standard dimensions



Safety brake prevents the leaf from dropping in case of cable damage



Overload safety device for automatic garage door

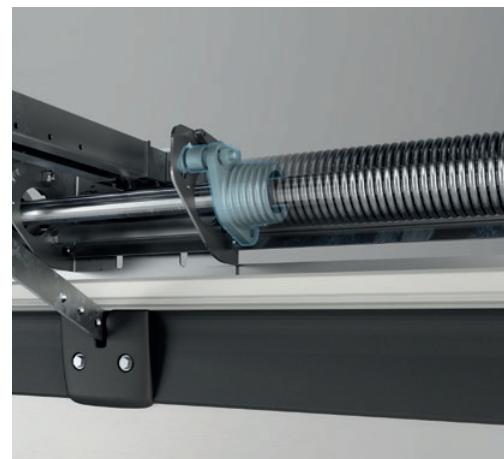

Integrated spring break safety device



Double rollers with bearings



Safe panel shape



Photocells - option



UniTherm.

Efficient thermal insulation.

The UniTherm garage door was developed in response to the requirements of energy efficient buildings. It fully benefits from the thermal insulation properties of the INNOVO 60 mm panel and the sealing solutions. This means higher energy efficiency of your home, because heat losses are eliminated in the most affected areas of the garage door leaf.

The INNOVO PANEL

The unique design of the INNOVO 60 mm panel provides an excellent heat transfer coefficient. It also constitutes a great framework for the lining. Special solutions, such as the 5-layer sheet bending system ensure stable fastening of elements, which further increases the strength of our design.



Heat transfer coefficient of the INNOVO panel $U_p = 0.33 \text{ W/m}^2\text{K}$.

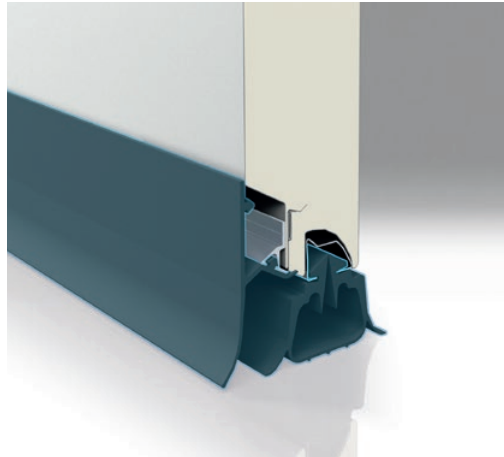

Double bottom gasket

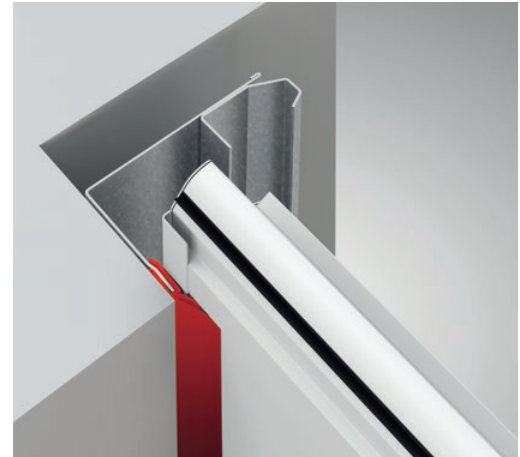

Double-lip circumferential seal

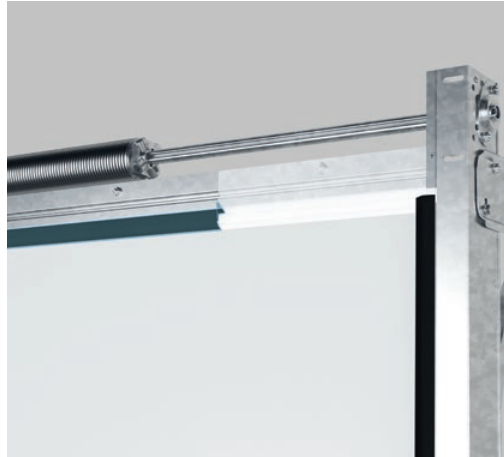

Double-lip gasket in the fascia panel

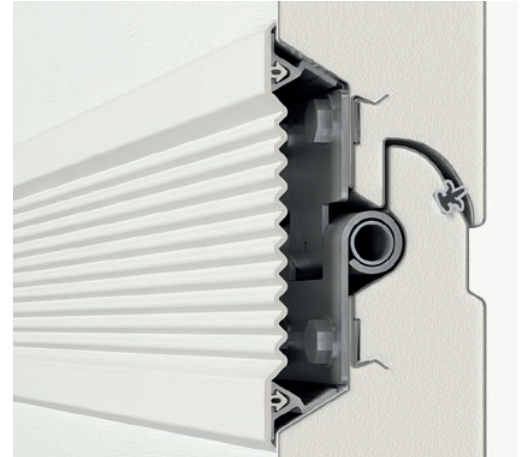

Panel joint seals

PRIME.

A new generation of garage doors.

Imagine a new generation of garage doors. A garage door which is not just another way of putting all the available solutions together, but an effect of a search for balance between modern technology, quality, safety, and design. This is what the PRIME door is all about. An innovative garage door, perfected in every detail, which meets your demands before you can even define them. With this fully equipped automatic door, every time you reach for the remote control, you can be sure that you made the right decision. PRIME is unrivalled – its classic design is just a hint of what this ingenious garage door hides inside.

Be the first, be PRIME. Find out about the exceptional advantages of our unique PRIME garage door!



**EXCLUSIVE
CLASS**





PRIME. Perfect in every detail.

PRIME means design focused on elegant and timeless simplicity, breaking with the purely functional approach to the garage door design. We have designed PRIME with attention to every single detail, because perfection depends on details.

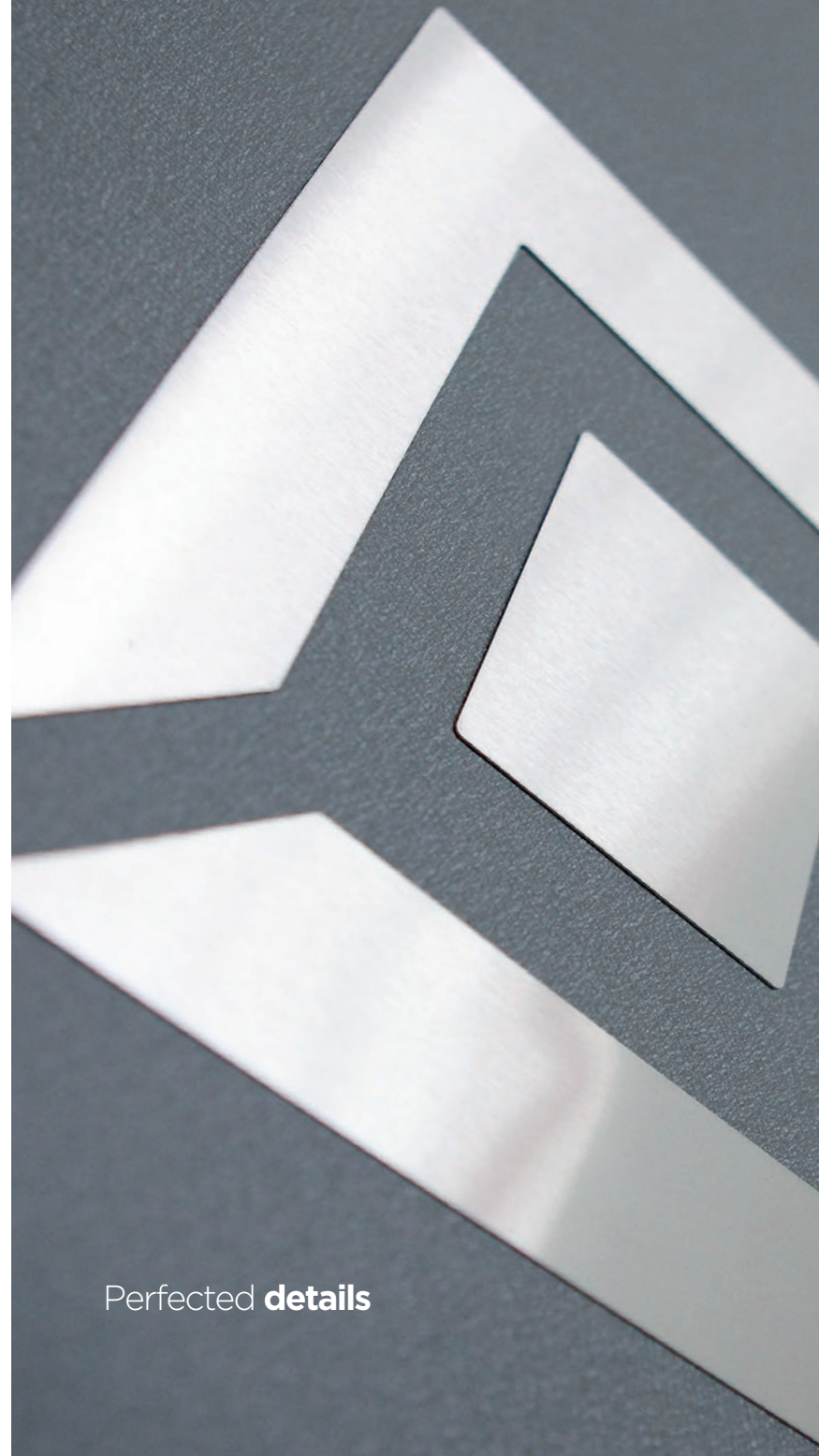

Perfected **details**



Exquisite **manufacturing**



Painted **elements of the construction**



PRIME.

A new definition of safety.

All the individual systems which make the garage door safe are interdependent and at the same time work in harmony with the structural parts. They include fixed guide covers, moving roller covers, an integrated spring and shaft cover, shaft and spring side covers, as well as flexible inner covers at panel joints.



1

Flexible panel joint covers



2

Vertical guide covers

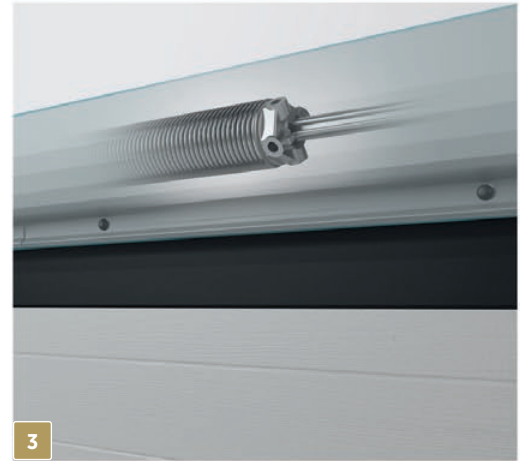

3

Integrated shaft and spring cover



4

Moving roller and guide covers



5

The Metro SMART io drive unit, compatible with the smartCONNECTED Box and TaHoma Switch central control units

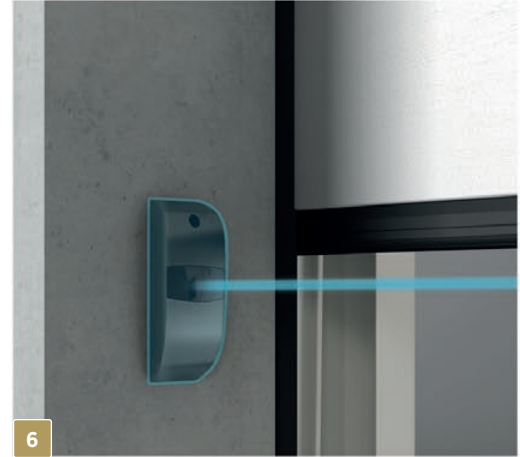

6

Photocells

PRIME.

An icon of safety.

PRIME does away with safety stereotypes. Not only is it a vision of a beautiful garage door, but also a reflection of our concern for safety. PRIME uses an end-to-end approach to safety and security. We used the technology not only to provide security, but most importantly to offer safety. The numerous advanced safeguards for structural parts and mechanisms help protect all the users and make your home this much safer. With a perfectly integrated drive system, PRIME is a technological trendsetter whose every detail shows that quality and safety are inextricably linked here.



SAFETY



Safety brake prevents the leaf from dropping in case of cable damage

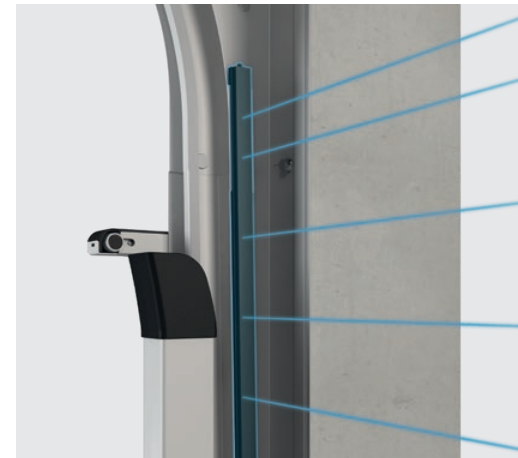

Safety light curtain - option

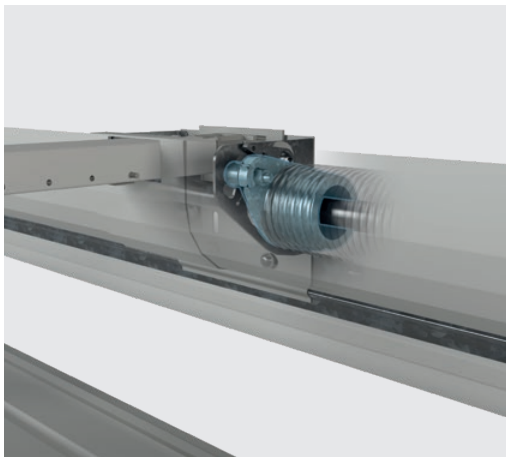

Integrated spring break safety device



Safe panel shape



Integrated shaft cover with side covers



Double rollers with bearings



Overload safety device



External optical sensors

PRIME. Major arguments for thermal insulation.

The PRIME garage doors are all about thermal insulation, which makes them a recommended choice for energy efficient and even passive buildings. PRIME answers the demand for maximum energy efficiency and minimum thermal losses in buildings.

In order to achieve this, it was necessary to reduce the heat transfer coefficient as much as possible. The PRIME garage door fully benefits from the thermal insulation properties of the INNOVO panel and our sealing solutions to eliminate heat losses in the most affected areas of the garage door leaf.

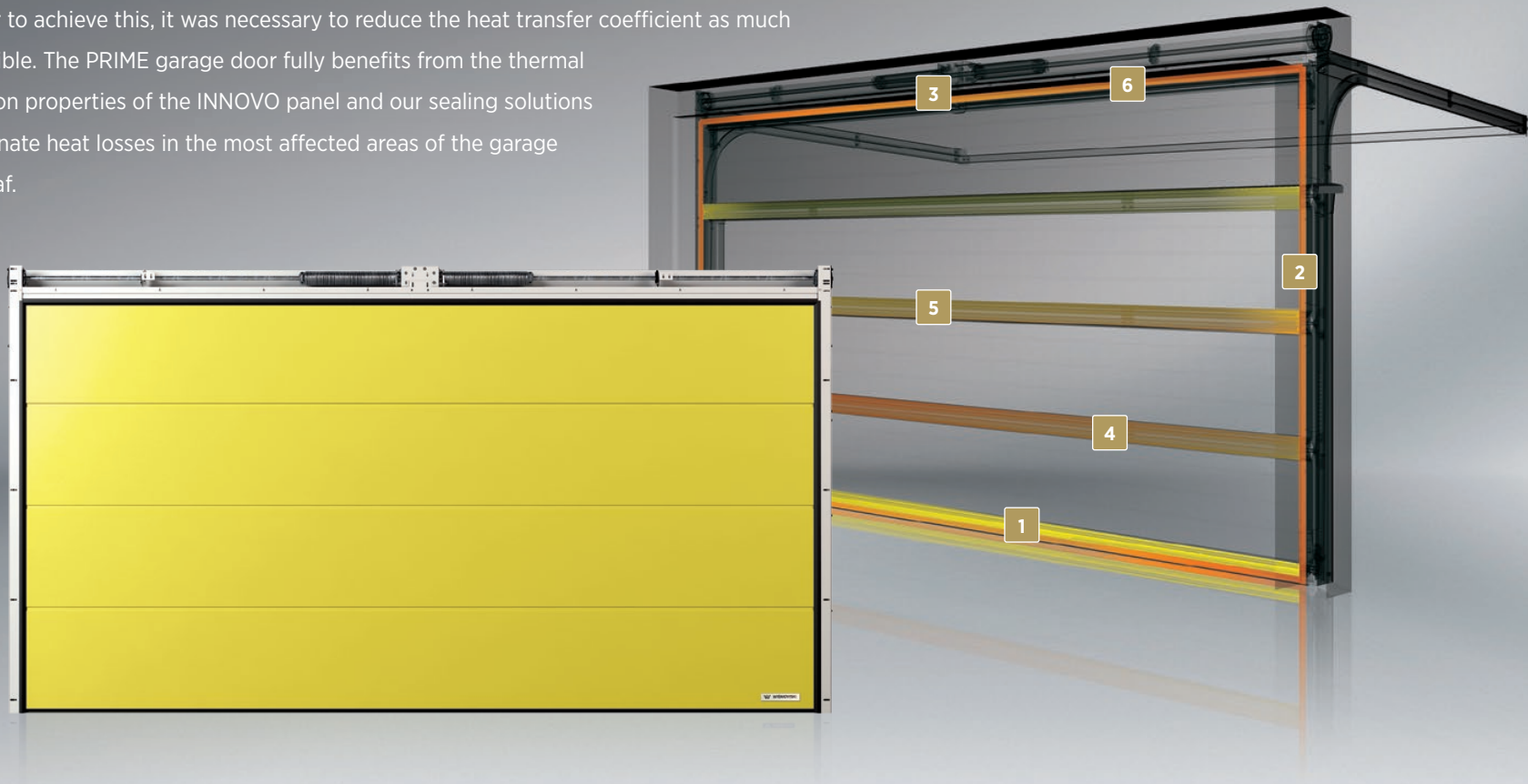



1

Double bottom gasket

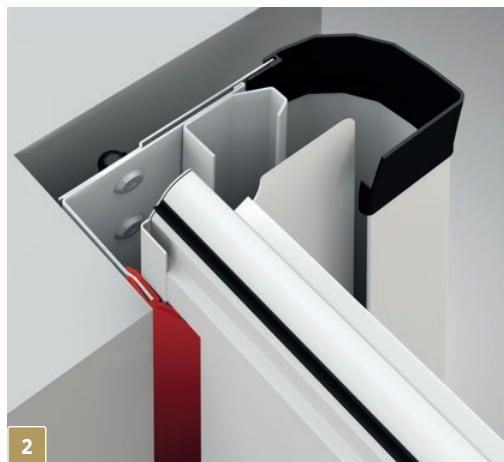

2

Double-lip circumferential seal



3

Double-lip gasket in the fascia panel

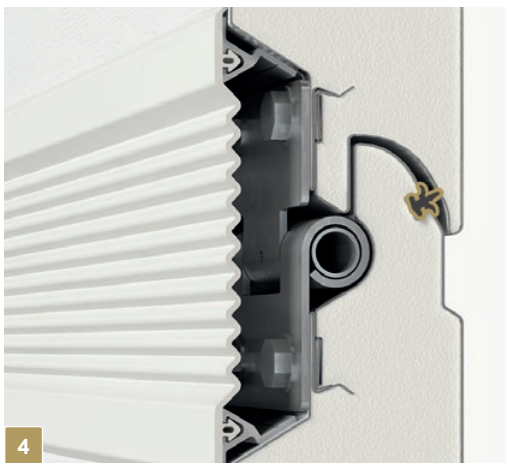

4

Panel joint seals



5

Flexible panel joint covers



6

Additional inner cover - for garage doors with standard dimensions

Renovation **solutions**

Renovation is all about adapting the functionality of the current building to the needs of its users. The aim of the refurbishment is usually to improve the aesthetic quality of the building.

Our renovation solutions let you install sectional garage doors in the garage opening regardless of the building conditions, even if the building has no lintel or side clearance. Enhance the functionality and the look of your garage with our renovation solutions.





UniPro **RenoSystem**

The UniPro RenoSystem is our response to the needs of buildings intended for renovation.

The structure is made of door frames adapted for installation in openings without the lintel or side clearance or with uneven wall surface. This structure comprises a fascia panel system in the same colour as the door leaf, which ensures great appearance without the need for further finishing works.

The RenoSystem solves a multitude of potential issues that could occur during the replacement of the garage door.

The structure is mounted directly to the existing surfaces with a system of angle bars which, paired with fascia panels, take over the functionality of the missing wall elements.



UNIVERSAL
INSTALLATION

Installation using lintel

Installation using frame



Installation behind the opening – fascia panel behind the opening



Installation in the opening – fascia panel in the opening

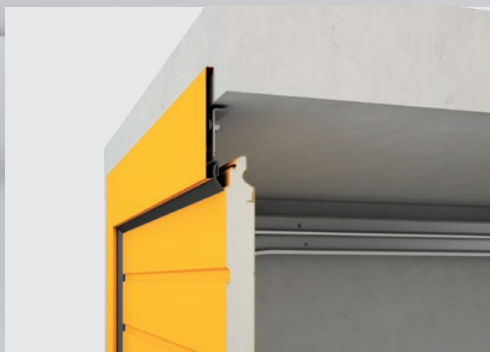

Installation in the opening – fascia panel in front of the opening

UniPro **SNP 2.0**

The UniPro SNP 2.0 and SSt 2.0 sectional garage door is dedicated primarily for buildings with a low lintel, with little space for torsion springs and narrow side clearance making it impossible to use traditional solutions. It is also used for renovation, particularly with imperfectly finished garage openings.

The UniPro SNP 2.0 and SSt 2.0 features a specially designed system of tracks and opening frames, which enables adjustment of the position of the door during fitting. Thanks to its proven structure, it is a reliable solution that is easy to install, which saves the customer's time and money.



1 Side gasket + opening frame fascia panel in the garage door colour



2 Tracks joined with the opening frame with screws



SSt 2.0 version



3 Universal installation method



4 950 mm mark



5 Pull spring system



UNIVERSAL
INSTALLATION



80 mm lintel

UniPro **Nano80**

The design of the **UniPro Nano80** garage door was adapted to the building conditions, where the low lintel prevents the installation of an automatic garage door. Thanks to its special track profile, the UniPro Nano80 automatic garage door can be installed even with **lintels just 80 mm high**, increasing the comfort for the garage users. Varied designs and a vast colour palette allow you to match the garage door to both traditional and modern buildings.



LINTEL

Sectional door installation structure

It is a modern and functional solution enabling the installation of sectional garage doors regardless of the building conditions in your garage. It acts as a framework and replaces the missing elements of the lintel or the side area where the structural elements of the garage door are mounted.

The structure is made of corrosion resistant galvanized steel and because fascia panels can be used in the door opening, the garage entrance maintains great appearance.



Renovation cladding panels

This solution makes it possible to match the front of the building with the design of the garage door curtain.

A perfect solution for owners of multi-car garages who appreciate a uniform style of buildings with a garage integrated with the building structure.



Renovation fascia panels

The garage door opening can be damaged in the process of replacing the garage door.

Fascia panels matching the door leaf colour can be used to cover up the damage or some less appealing building structure features.



Renovation fascia panel - option

Finishing thermal seal

Makes it possible to provide an aesthetic finish of the garage opening thermally insulated for example with a layer of polystyrene or Styrodur by eliminating the clearance between the thermal insulation layer and the door leaf surface, which improves thermal insulation.

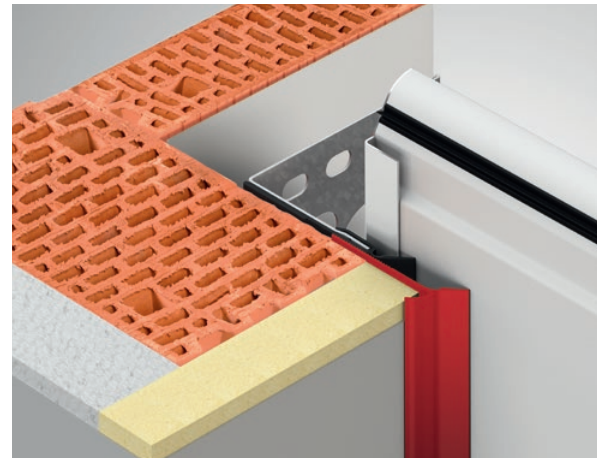

Finishing thermal seal - option



Structures, versions, colours



STRUCTURES



Woodgrain



Smoothgrain



Sandgrain

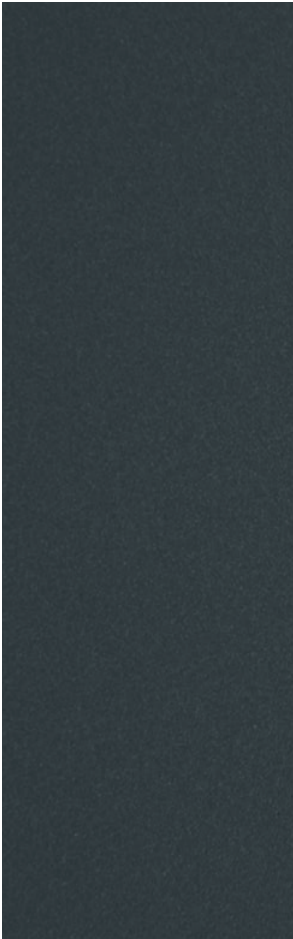

Silkline



Silkline,
panel with V ribs

DESIGNS



Garage door with panels without ribs



Garage door with panels with high ribs



Garage door with panels with low ribs



Garage door with panels with caisson ribs



Garage door with panels with V ribs

GLAZING



Garage door with portholes - type A-1



Garage door with portholes - type C-1



Garage door with portholes - type E-1



Garage door with portholes - type O



Garage door with portholes- type O-1A, stainless steel porthole frame



Garage door with portholes- type O-2A, stainless steel porthole frame



Garage door with portholes- type R-1A, stainless steel porthole frame



Garage door with portholes- type R-2A, stainless steel porthole frame



Garage door with portholes - type W3-1



Garage door with portholes - type W4-1



Garage door with portholes - type W5-1



Garage door with portholes - type W6-1



DECORATIVE MOTIFS



Type Ap-1



Type Ap-2



Type Ap-3



Type Ap-4



Type Ap-5



Type Ap-6



Ap-7 type in the door with panels without ribs



Ap-7 type in the door with panels with high ribs

VERSIONS



Garage door with VISUAL glazing
- the VISUAL panel is available for garage door widths up to So=3000 [mm].



Garage door with the HORIZON glazing
- with garage door widths up to So = 3,000 [mm]



Garage door with an aluminium panel glazing



Garage door with wicket door



21 mm



Garage door with a ventilated panel -
perforated sheet

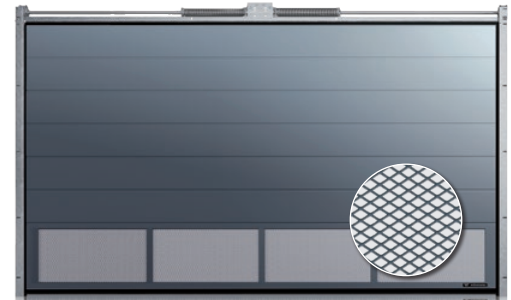

Garage door with a ventilated panel -
expanded mesh panel

SIDE DOOR DESIGNS



Side door with panels without ribs



Side door with panels with high ribs



Side door with panels with low ribs



Side door with panels with caisson ribs



Side door with panels with V ribs



Side door with the A-1 glazing



Side door with the Ap-4 decorative motif

An abundance of colours

Colour is the first feature our senses react to. We made sure that each of our customers can find the colour they are looking for. Our garage doors can be manufactured in RAL palette colours and in wood effect colours – together with our range of structures and extra decorative elements, this gives you hundreds of options for a tailored solution.



RAL palette colours, wood, steel, and other surface finish effects

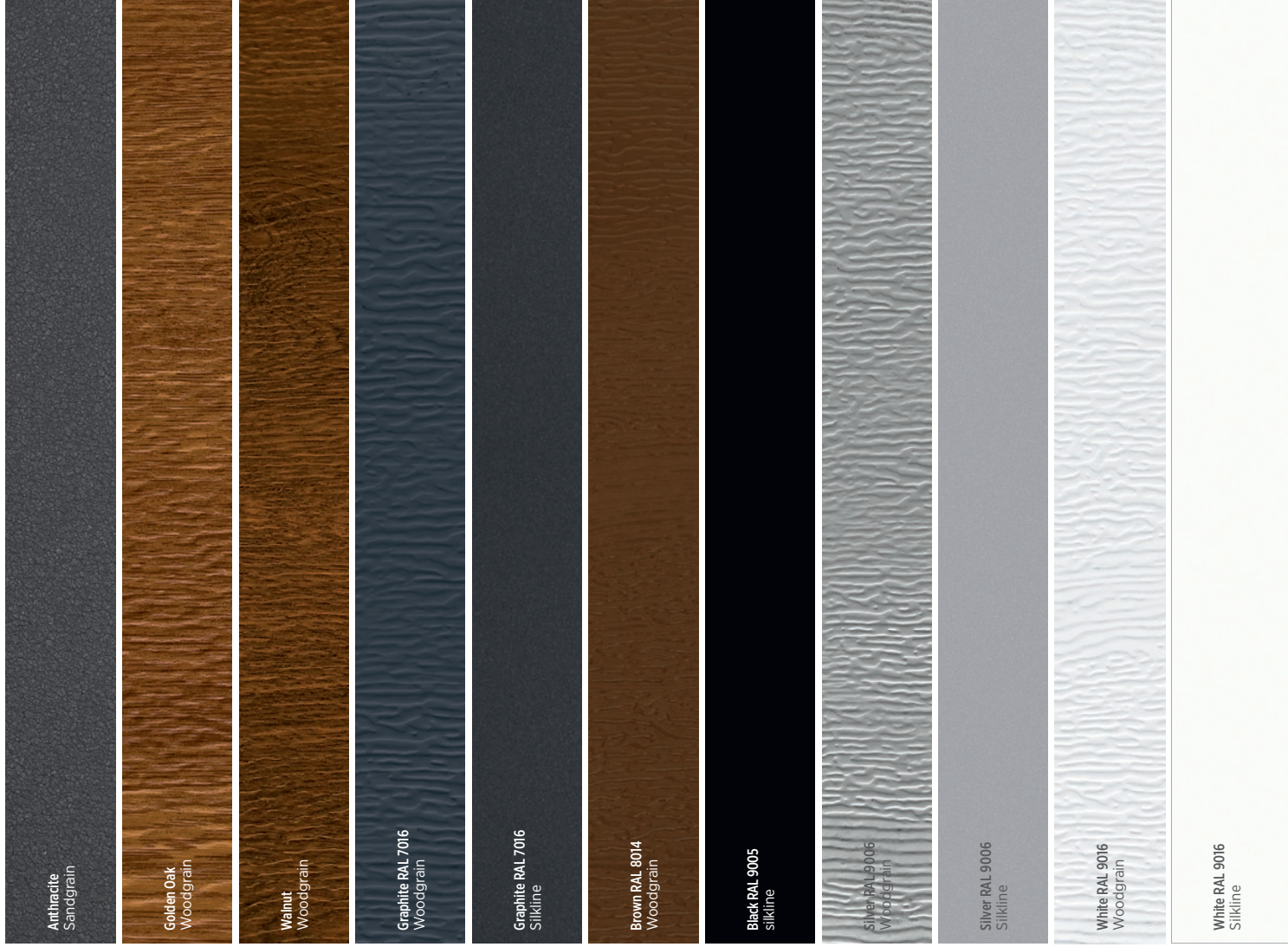

NO RIBS	● ▲ ■	■	■	■	● ▲ ■	■	■	■	■	● ▲ ■
HIGH RIBS	● ▲ ■	■	■	■	● ▲ ■	■	■	■	■	● ▲ ■
LOW RIBS		■	■	■	■	■	■	■	■	
V RIBS								■		
CAISSON RIBS		■							■	

- PRIME
- ▲ UniTherm
- UniPro

All sectional garage door panels with Woodgrain and Silkline structure are available in RAL colours.

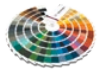

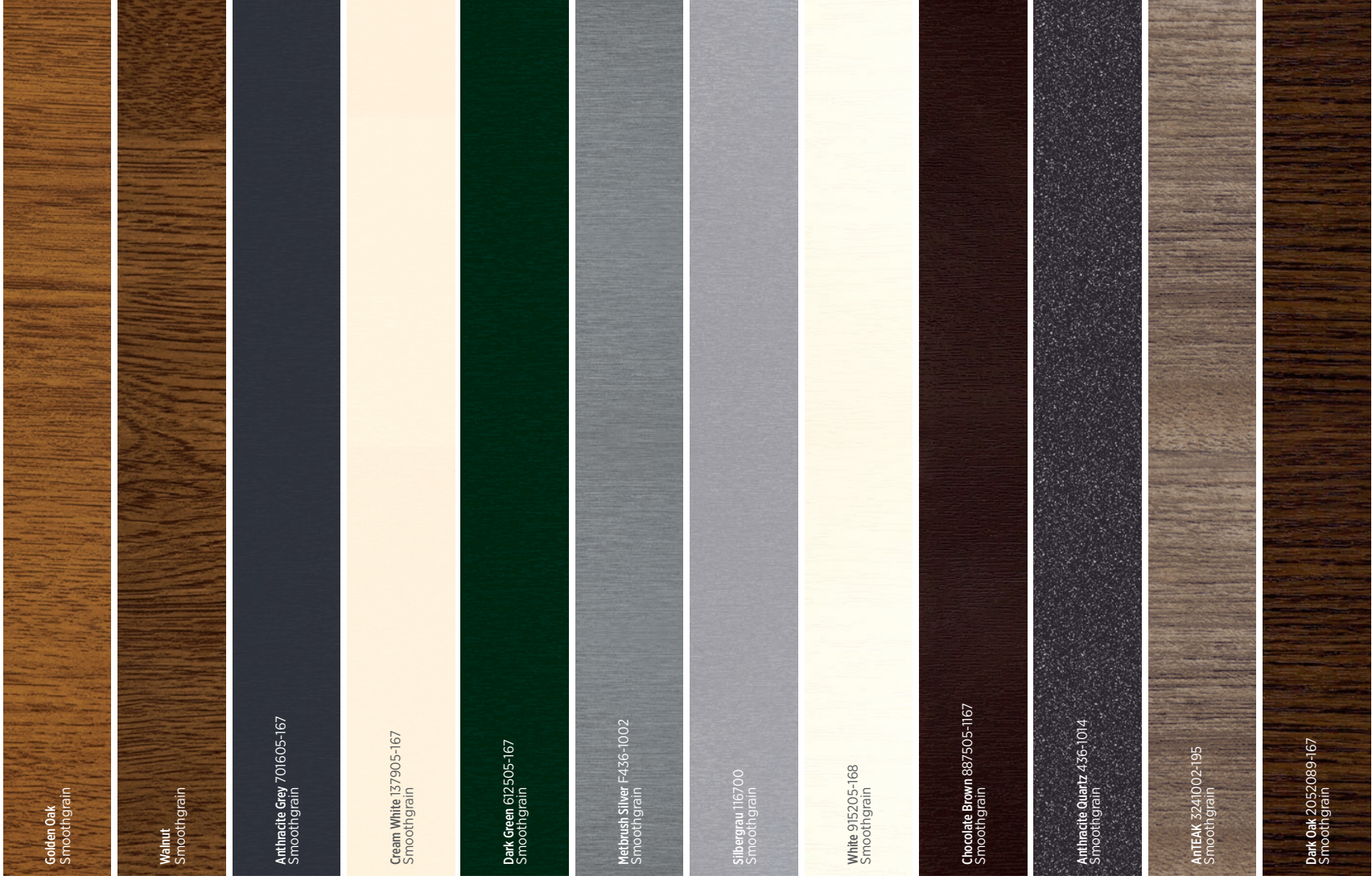

NO RIBS	● ▲ ■	● ▲ ■	● ▲ ■	● ▲ ■	● ▲ ■	● ▲ ■	● ▲ ■	● ▲ ■	● ▲ ■	● ▲ ■	● ▲ ■	● ▲ ■
HIGH RIBS	● ▲ ■	● ▲ ■	■	■	■	■	■	■	■	■	■	■
LOW RIBS												
V RIBS												
CAISSON RIBS												

- PRIME
- ▲ UniTherm
- UniPro

Swamp Oak 3167004-167
Smoothgrain

Summer Cherry 3214009-195
Smoothgrain

Macore 3162002-167
Smoothgrain

Oregon 1192001-167
Smoothgrain

Sapelli 2065021-167
Smoothgrain

Siena Noce 49237 PN
Smoothgrain

Siena PL 49254-015
Smoothgrain

Siena Rosso 49233 PR
Smoothgrain

Winchester 49240 XA
Smoothgrain

Black Cherry 3202001-167
Smoothgrain

Natural Oak 3118076-1168
Smoothgrain

Douglas Fir 3152009-1167
Smoothgrain

Rustic Oak 3149008-167
Smoothgrain

Sheffield Oak Brown F 4136-3087
Smoothgrain



All sectional garage door panels with Woodgrain and Silkline structure are available in RAL colours.



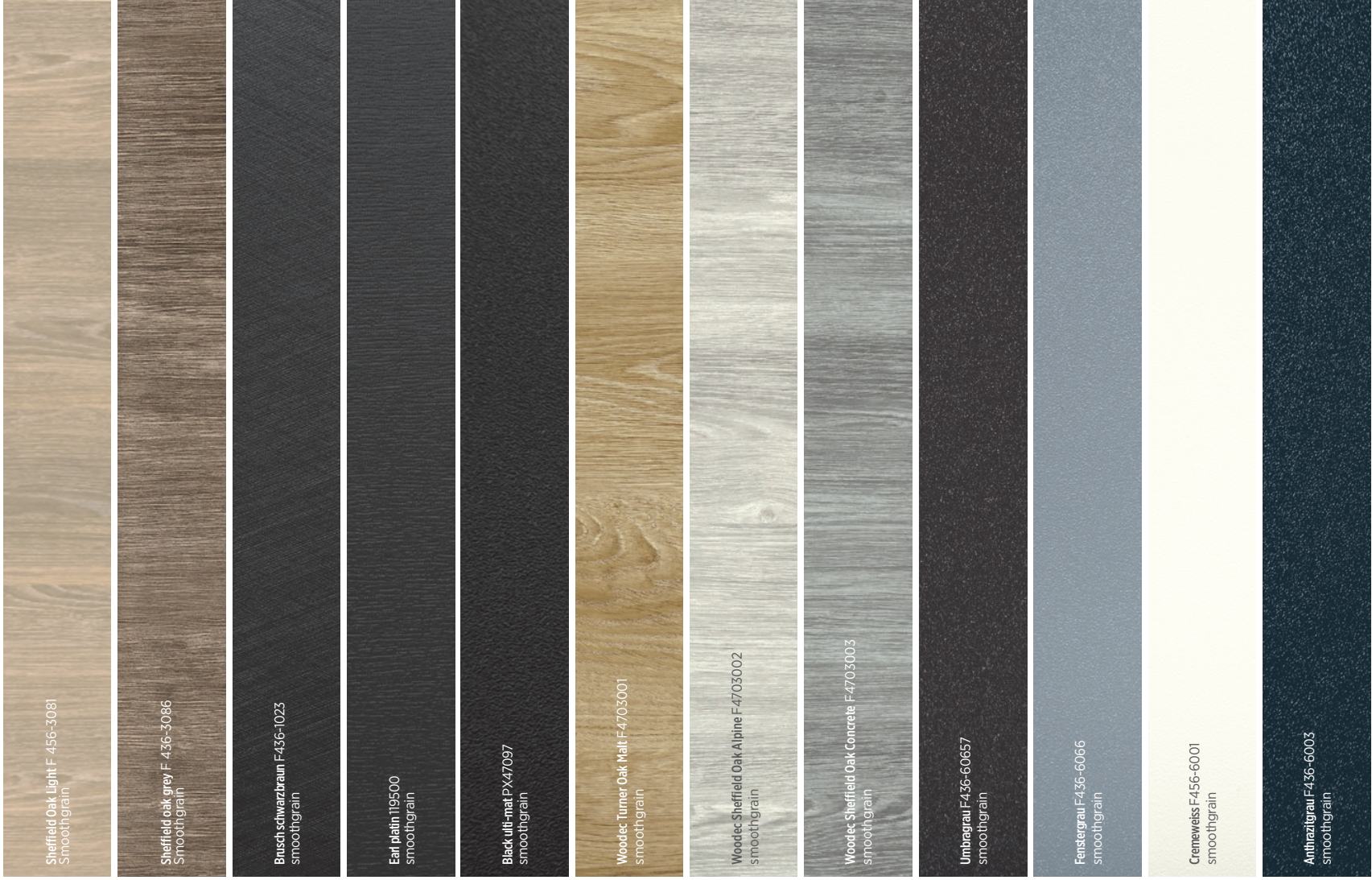

NO RIBS	● ▲ ■	● ▲ ■	● ▲ ■	● ▲ ■	● ▲ ■	● ▲ ■	● ▲ ■	● ▲ ■	● ▲ ■	● ▲ ■	● ▲ ■	● ▲ ■
HIGH RIBS	● ▲ ■	● ▲ ■	■	■	■	■	■	■	■	■	■	■
LOW RIBS												
V RIBS												
CAISSON RIBS												

- PRIME
- ▲ UniTherm
- UniPro

Dark grey silk 4367003
smoothgrain

Golden Oak 2178001-167
smoothgrain

Walnut 2178007-167
smoothgrain

Anthracite Quartz Mat F.4701014
smoothgrain

Woodtec Turner Oak Toiffe F.4703004
smoothgrain



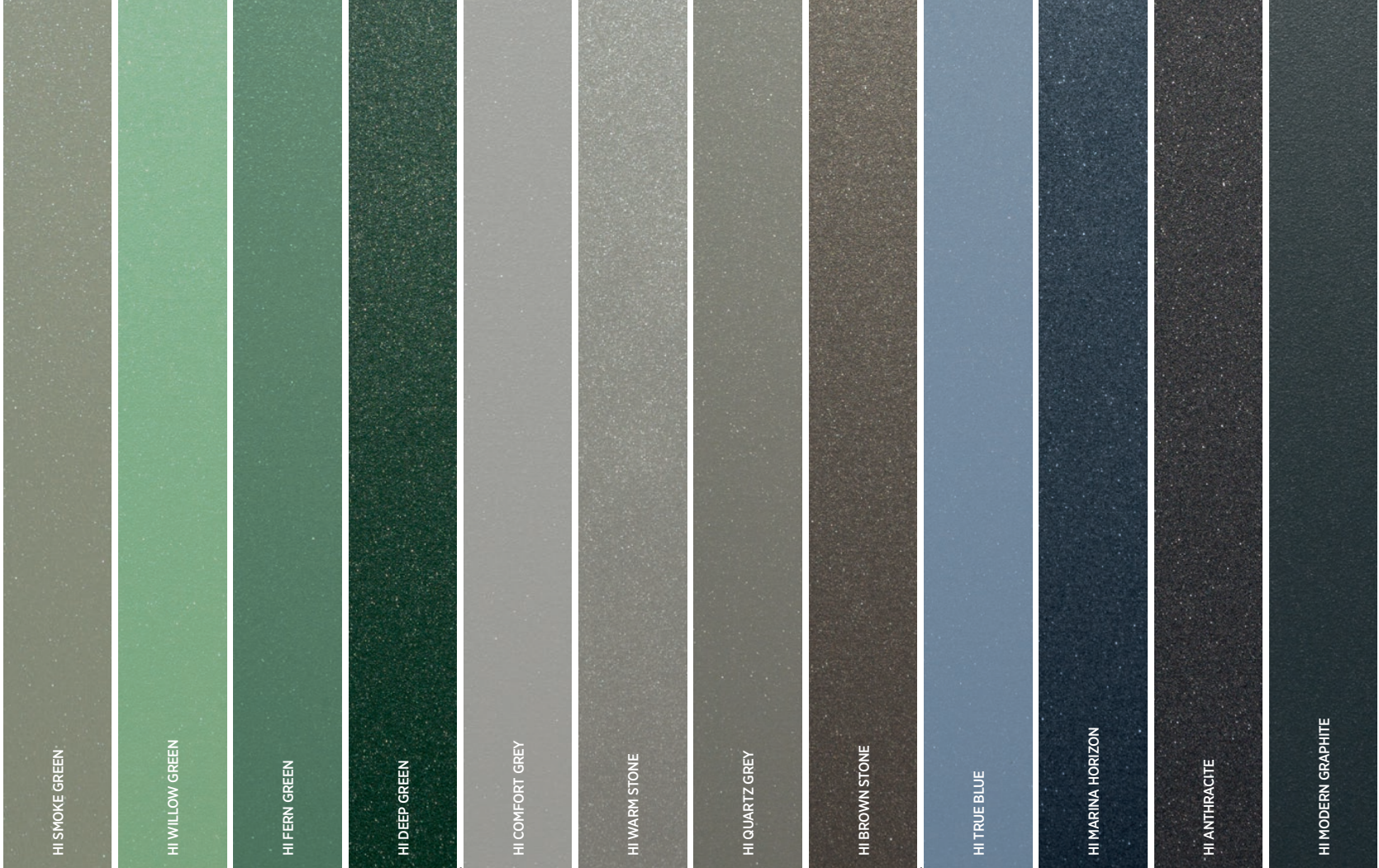

HI EARTH

HI STONE

HI STEEL

NO RIBS	● ▲ ■	● ▲ ■	● ▲ ■	● ▲ ■	● ▲ ■	● ▲ ■	● ▲ ■	● ▲ ■	● ▲ ■	● ▲ ■	● ▲ ■	● ▲ ■
HIGH RIBS	● ▲ ■	● ▲ ■	● ▲ ■	● ▲ ■	● ▲ ■	● ▲ ■	● ▲ ■	● ▲ ■	● ▲ ■	● ▲ ■	● ▲ ■	● ▲ ■
LOW RIBS	■	■	■	■	■	■	■	■	■	■	■	■
V RIBS												
CAISSON RIBS												

- PRIME
- ▲ UniTherm
- UniPro



HI MOODY CORAL

HI FLAME RED

HI MODERN MAROON

HI DEEP BROWN

HI RUBY

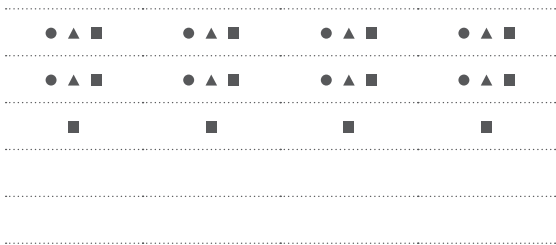

NEW COLOURS!
HOME INCLUSIVE^{2.0}

THE HOME INCLUSIVE 2.0 COLOUR COLLECTION

Add exceptional character to your property thanks to the unique depth effect of HI 2.0 colours.





HANDLE COLLECTION



KL-2 handle, colour: RAL 9006

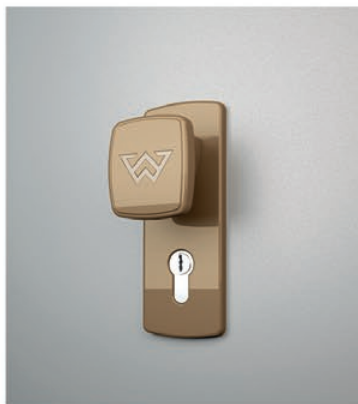

KL-2 handle, colour: RAL 1036



KL-2 handle, colour: RAL 1035



KL-2 handle, colour: RAL 7048



KL-2 handle, colour: RAL 9016



KL-2 handle, colour: RAL 9005



KL-2 handle, colour: RAL 8014

Automatic **garage** **doors**

Treat yourself to comfort and safety with our automatic garage doors. Our finely designed garage doors are configured with a reliable drive unit for a complete device that makes your life that much easier. Our garage doors come with documents confirming that they meet all the functional and safety requirements. The CE mark is a crucial element for the driven garage door, as it backs the declaration of conformity with the stringent European standards.

Professional care of the automatic garage door and its good operation is ensured by the EXTENDED CARE warranty. It lets you extend the standard warranty for the complete product – automatic sectional garage door:

- up to 5 years when factory configured with the METRO drive unit,
- up to 3 years when factory configured with the MOTO drive unit.





5 years
WARRANTY
EXTENDED CARE

on automatic garage doors
with the **METRO** drive unit

 **WIŚNIEWSKI**

3 years
WARRANTY
EXTENDED CARE

on automatic garage doors
with the **MOTO** drive unit

 **WIŚNIEWSKI**

EXTENDED CARE warranty
lets you extend the standard warranty up to:

- 5 years for the complete product – automatic sectional garage door factory configured with the **METRO** drive unit,
- 3 years for the complete product – automatic sectional garage door factory configured with the **MOTO** drive unit.



TREAT YOURSELF TO COMFORT AND SAFETY

The smartCONNECTED concept brings WIŚNIOWSKI automatic garage doors to the next level of product development and tailors them to the requirements of more and more demanding customers.

On the one hand, it lets you control the devices with your smartphone, and on the other, it gives you full control and lets you stay in touch with your home from any place in the world. Modern, safe, and reliable io-homecontrol radio technology allows you to connect the Metro SMART io drive to the smartCONNECTED device by WIŚNIOWSKI and TaHoma device by Somfy, which gives the drive unit further functionality and connects the garage door with other smart devices in your home.





I am smartCONNECTED

The functionality behind the smartCONNECTED name is an investment that benefits your entire family, because to enter your home, you no longer need to lug around a weighty bunch of keys. Parents can let their children inside without leaving the office. You can also check whether the gate is closed by using your smartphone. What is more, thanks to the use of algorithms, your smart home can memorize the lifestyle of its inhabitants and perform basic actions, such as opening and closing the roller shutters for them. And with the global positioning function, it can also open the gate just before you arrive home.





TREAT YOURSELF TO COMFORT AND SAFETY

- Control your garage doors, gates, windows, doors, and roller shutters remotely.
- Open garage doors and gates without touching your remote.
- Manage your home via a voice assistant.



WIŚNIEWSKI POWERED BY somfy.

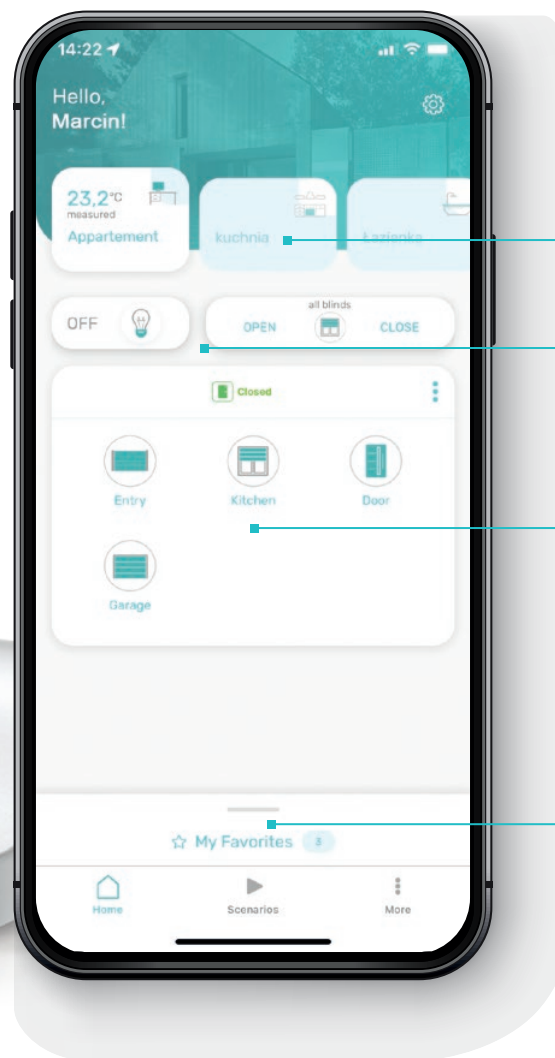

CREATE A ROOM in your home.

CONTROL GROUPS OF lights and roller shutters.

CONTROL INDIVIDUAL devices.

Create YOUR OWN OPERATION SCENARIOS.

The SmartCONNECTED technology brings WIŚNIEWSKI automatic sectional garage doors to the next level of product development, tailoring them to the requirements of increasingly demanding customers. On the one hand, it makes it possible to control the devices with a smartphone, and on the other, it gives the users full control and lets them stay in touch with their home from any place in the world. io-homecontrol® enables wireless connection of the Metro SMART io drive unit to the smart home system controlled by the WIŚNIEWSKI smartCONNECTED Box and Somfy TaHoma Switch central control units. Building a comprehensive smart home provides a number of benefits and additional features that enhance your comfort every single day.

METRO drive

METRO is a new generation of drive units. It is a harmonious combination of power, beauty, and reliability, designed using state-of-the-art technology. It is the result of cooperation between **WIŚNIEWSKI** and **Somfy**, a leading global manufacturer of automation products and smart control solutions for home devices. The METRO drive features exceptional technical parameters in an enclosure designed according to the WIŚNIEWSKI design principles.

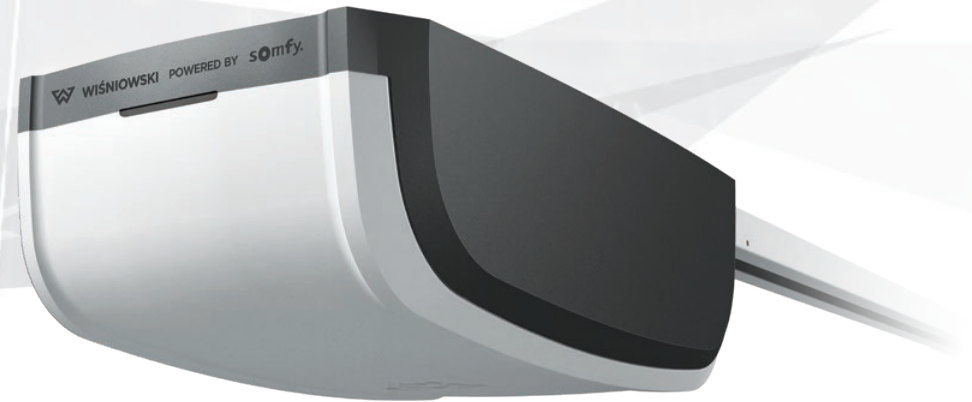



PULSAR
four-channel transmitter



METRO, MOTO

TECHNICAL DATA



		Moto RTS	Metro RTS	Metro SMART io
Application	sectional (garage) doors	•	•	•
	up and over (garage) doors	•	•	•
Simple programming		•	•	•
Auto selection of operating parameters		•	•	•
Configurable		•	•	•
Display		–	•	–
Safety	Obstacle detection	•	•	•
	Photocells	•	•	•
Radio transmission	RTS	•	•	–
	io	–	–	•
Backup power supply		•	•	•
Cycle counter		–	•	... ⁽²⁾
Integrated signal light		•	•	•
Additional safeguard	Mechanical carriage lock	•	•	•
Stand-alone, additional external lamp		•	•	•
Recent fault logging		–	•	... ⁽²⁾
90° head adjustment		•	•	•
Steel rail with a chain or belt		•	•	•
Smart technologies	Ri-Co	•	•	•
	smartCONNECTED Box	–	–	•
	TaHoma Premium	• ⁽¹⁾	• ⁽¹⁾	•
Garage ventilation feature		–	–	•
Remote control				
		PULSAR transmitter two-channel	PULSAR transmitter four-channel	smartphone app

⁽¹⁾ Control with no feedback.

⁽²⁾ Only with Set&Go



homecontrol®

is a modern, safe, and reliable radio technology by Somfy that lets you control your devices compatible with the smart home concept. Thanks to this technology, the drive unit not only receives commands from controllers, but it can also send feedback. The io-homecontrol technology makes it possible to connect the Metro SMART io drive to the TaHoma and smartCONNECTED Box system, which provides the drive with additional functions that connect the garage door with smart devices available in your home.



MOTO drive unit

The MOTO drive unit ensures reliable operation with functions typical of drive units from the economy segment.

Main features and functions:

- simple programming – ready to use in under 60 seconds,
- overcurrent obstacle detection,
- RTS radio transmission,
- integrated LED signal light,
- track beam with a chain,
- two drive versions,
- compatible with an external signal light,
- compatible with photocells,
- compatible with emergency power supply battery.



PULSAR RTS
two-channel transmitter



Digipad RTS code keypad by Somfy

The two-channel code keypad makes it possible to control both drive units and radio receivers. Thanks to radio communication, they can be installed in any place and don't need any cables.

ACCESSORIES FOR AUTOMATIC OPERATING UNITS FOR **GARAGE DOORS**

Extra features offered by the automatic garage door equipment equal higher safety standards and more comfort.

Set&Go by Somfy

is a device that guides the user through all the configuration steps of the io-homecontrol automatic operating unit. The device includes an antenna and a PC application.



io code keypad by Somfy

lets you control the io radio drives and can support up to two devices. The keypad is a flush-mounted wireless device and no cables are required for installation. The device is powered with a battery and features backlit keys.



RTS wall-mounted transmitter by Somfy

The two-channel transmitter lets you control both your drive units and radio receivers. Thanks to radio communication, they can be installed in any place and don't need any cables.



The external radio receiver by Somfy

lets you control the drive units using the Pulsar transmitter. It is a two-channel device where you can program as many as 16 transmitters.



The mechanical carriage lock

is an additional safeguard which increases garage door safety when mounted to the carriage.

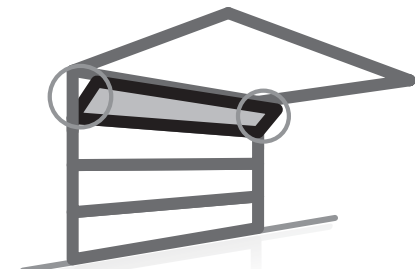

Garage ventilation feature

is enabled by tilting the top panel without the need to lift the door. The bottom panel remains seated against the floor.



Warning lamp

compatible with the METRO drives.



Backup battery

connected to the METRO and MOTO drive provides power for several cycles of emergency operation.



External code keypad

this single-channel device can be used to control the garage door with a code. For outdoor installation, requires cabling.



Photocells

prevent uncontrolled door leaf movement when an obstacle is present within the clear passage.

INSPIRATION

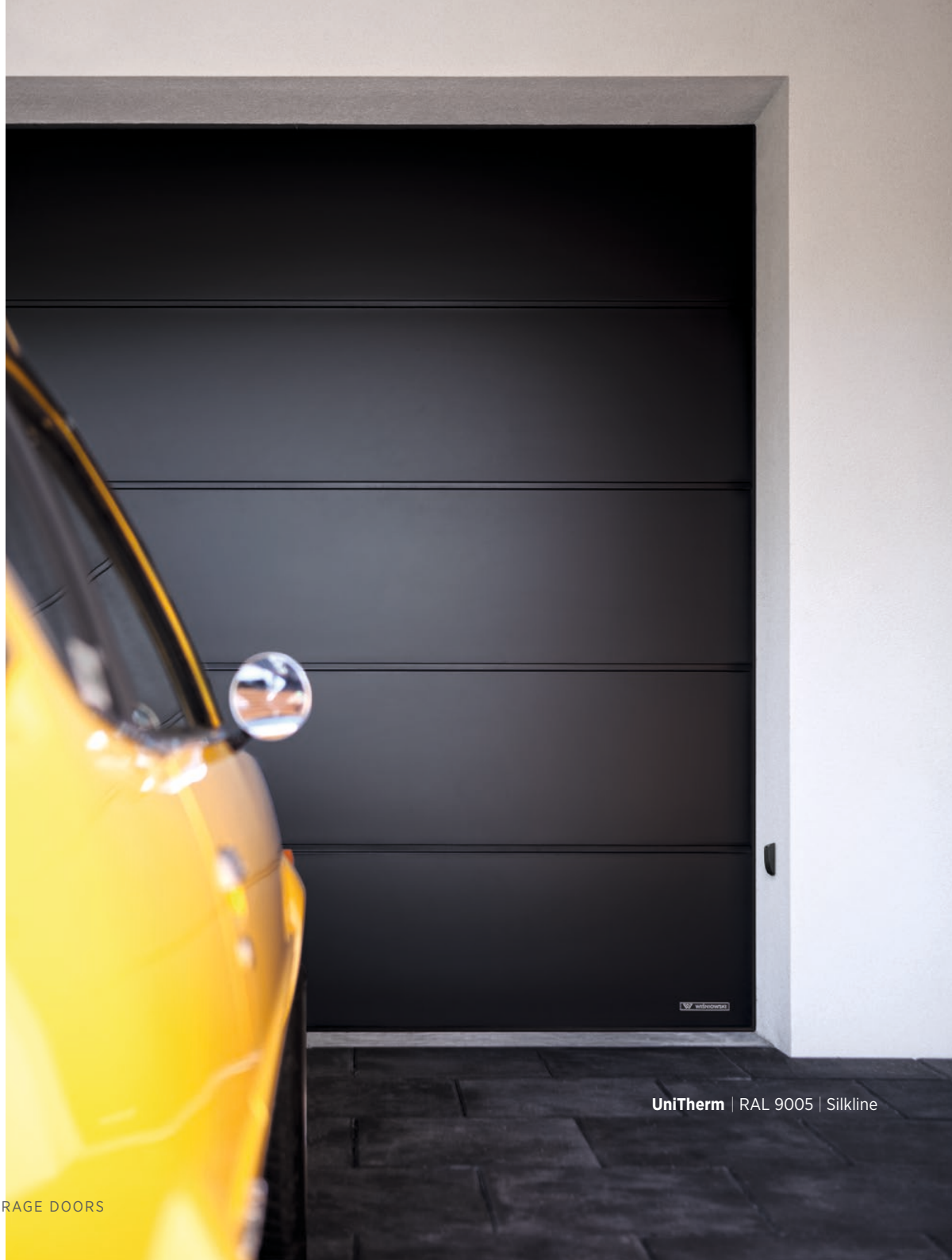

UniTherm | RAL 9005 | Silkline





UniPro | HI MODERN GRAPHITE
LUX | AW.10.54 | HI MODERN GRAPHITE
CREO | 310 | HI MODERN GRAPHITE

INSPIRATION



PRIME | Anthracite Grey | Smoothgrain



UniPro | RAL 3000 | Silkline
CREO | 345 | Sheffield Oak Light

INSPIRATION



UniPro | RAL 7040 | Woodgrain





PRIME | RAL 2011 | Silkline

INSPIRATION



UniTherm | Sheffield Oak Light | Smoothgrain
CREO | 345 | Sheffield Oak Light

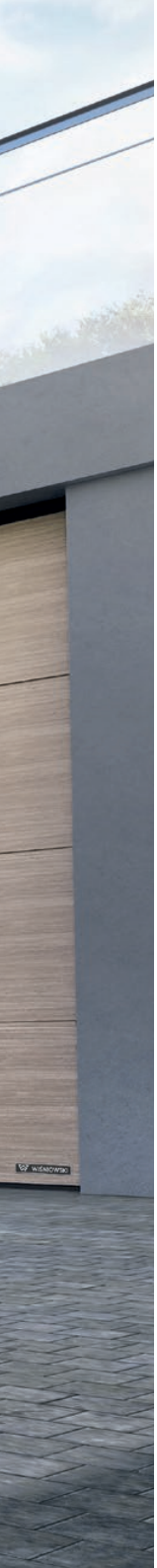

UniPro | Anthracite | Sandgrain

INSPIRATION



UniPro | Anthracite | Sandgrain
DECO | 145 | RAL 7037 | matt structure





PRIME | RAL 7035 | Silkline
CREO | 321 | RAL 7035 | matt structure

INSPIRATION



side door | Walnut | Smoothgrain



UniPro | RAL 7016 | Silkline
side door | RAL 7016

INSPIRATION



UniTherm | RAL 9016 | Silkline
CREO | 331 | RAL 9016 | matt structure



UniTherm | Natural Oak | Smoothgrain



UniTherm | HI MODERN GRAPHITE
CREO | 321 | HI MODERN GRAPHITE

INSPIRATION



UniPro RenoSystem | RAL 9004 | silkline



UniTherm | Winchester | Smoothgrain

INSPIRATION



PRIME | RAL 7016 | silkline

Technical information

U thermal transmittance factor [W/m²K] for the UniPro sectional doors (40 [mm] panel)

		Door width in [m]																	
		2.250	2.375	2.400	2.500	2.600	2.750	3.000	3.250	3.500	3.750	4.000	4.250	4.500	4.750	5.000	5.250	5.500	6.000
Door height in [m]	2.000	1.3	1.3	1.3	1.3	1.3	1.3	1.3	1.3	1.3	1.3	1.3	1.3	1.3	1.3	1.3	1.2	1.2	1.2
	2.100	1.3	1.3	1.3	1.3	1.3	1.3	1.3	1.3	1.3	1.3	1.3	1.2	1.2	1.2	1.2	1.2	1.2	1.2
	2.125	1.3	1.3	1.3	1.3	1.3	1.3	1.3	1.3	1.3	1.3	1.2	1.2	1.2	1.2	1.2	1.2	1.2	1.2
	2.200	1.3	1.3	1.3	1.3	1.3	1.3	1.3	1.2	1.2	1.2	1.2	1.2	1.2	1.2	1.2	1.2	1.2	1.2
	2.250	1.3	1.3	1.3	1.3	1.3	1.3	1.2	1.2	1.2	1.2	1.2	1.2	1.2	1.2	1.2	1.2	1.2	1.2
	2.375	1.3	1.3	1.3	1.3	1.3	1.3	1.2	1.2	1.2	1.2	1.2	1.2	1.2	1.2	1.2	1.2	1.2	1.2
	2.500	1.3	1.3	1.3	1.3	1.3	1.3	1.2	1.2	1.2	1.2	1.2	1.2	1.2	1.2	1.2			
	2.625	1.3	1.3	1.3	1.3	1.3	1.3	1.3	1.3	1.2	1.2	1.2							
	2.750	1.3	1.3	1.3	1.3	1.3	1.3	1.2	1.2	1.2	1.2	1.2							
	2.875	1.3	1.3	1.3	1.3	1.3	1.3	1.2	1.2	1.2	1.2								
3.000	1.3	1.3	1.3	1.3	1.3	1.3	1.2	1.2	1.2										

U thermal transmittance factor [W/m²K] for the UniTherm and PRIME sectional doors (INNOVO 60 [mm] panel)

		Door width in [m]																
		2.250	2.375	2.400	2.500	2.600	2.750	3.000	3.250	3.500	3.750	4.000	4.250	4.500	4.750	5.000	5.500	6.000
Door height in [m]	2.000	1.1	1.1	1.1	1.1	1.1	1.1	1.1	1.1	1	1	1	1	1	1	1	1	0.99
	2.100	1.1	1.1	1.1	1.1	1.1	1.1	1	1	1	1	1	1	1	0.99	0.99	0.98	0.97
	2.125	1.1	1.1	1.1	1.1	1.1	1.1	1	1	1	1	1	1	0.99	0.99	0.98	0.97	0.97
	2.200	1.1	1.1	1.1	1.1	1	1	1	1	1	1	0.99	0.98	0.98	0.97	0.97	0.96	0.95
	2.250	1.1	1.1	1.1	1	1	1	1	1	1	0.99	0.98	0.97	0.97	0.96	0.96	0.95	0.94
	2.375	1	1	1	1	1	1	1	0.99	0.98	0.97	0.96	0.95	0.95	0.94	0.94	0.93	0.92
	2.500	1.1	1.1	1.1	1.1	1.1	1.1	1.1	1	1	1	1	1	1	1	1		
	2.625	1.1	1.1	1.1	1.1	1.1	1.0	1.0	1.0	1.0	1	1						
	2.750	1.1	1.1	1.1	1.0	1.0	1.0	1.0	1.0	1.0	0.99	0.98						
	2.875	1.0	1.0	1.0	1.0	1.0	1.0	1.0	0.99	0.98	0.97							
3.000			1.0	1.0	1.0	1.0	0.98	0.97	0.96									

The factors are provided for doors without glazing, wicket doors, ventilation grilles, aluminium panels, and additional thermal gaskets.

Technical information

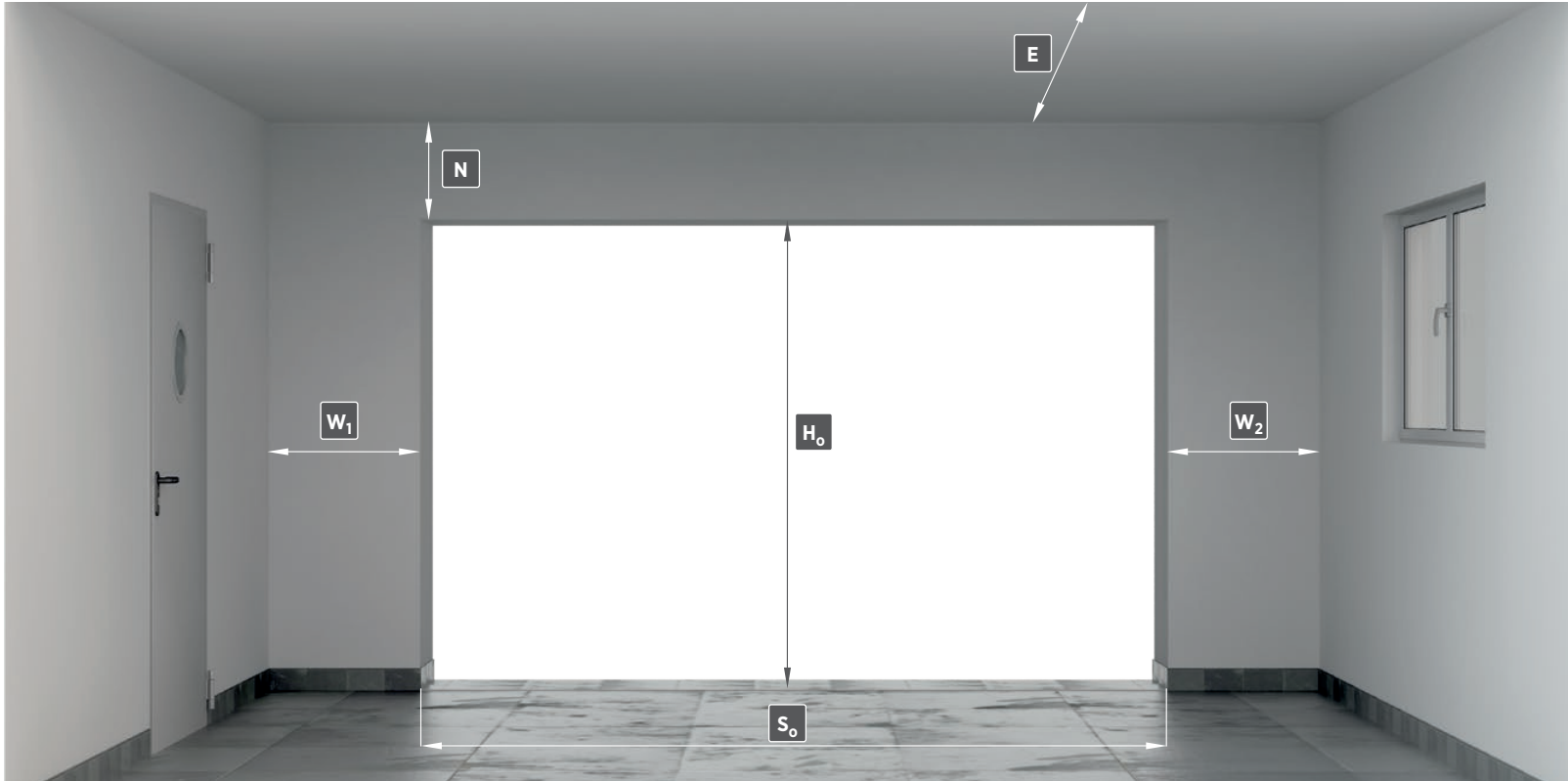

- S_o** - opening width, ordering dimension
- H_o** - opening height, ordering dimension
- N** - minimum required lintel height

- W₁** - minimum required side clearance
- W₂** - minimum required side clearance
- E** - minimum garage depth with clearance under the ceiling

TYPES OF TRACKS

- N** – pull springs, garage door with double horizontal tracks,
- Sp** – torsion springs installed in the front by the lintel, garage door with double horizontal tracks,
- St** – torsion springs installed at the end of horizontal tracks, garage door with double horizontal tracks,
- Sj** – torsion springs installed in the front by the lintel, garage door with single horizontal tracks (the UniTherm garage door is fitted with auxiliary reinforcing tracks),
- SpA** – tracks at an angle, torsion springs installed in the front by the lintel,
- StA** – tracks at an angle, torsion springs installed at the end of diagonal tracks,
- HL** – high tracks, torsion springs installed by the lintel,
- NP** – pull springs mounted along the vertical tracks.

PANEL TYPES FOR SECTIONAL GARAGE DOORS

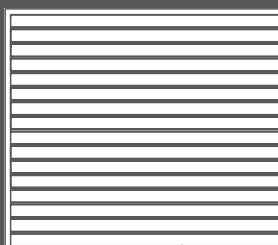

N - low ribs

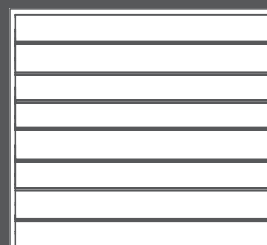

W - high ribs

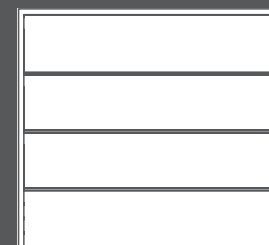

G - no ribs



V - V ribs

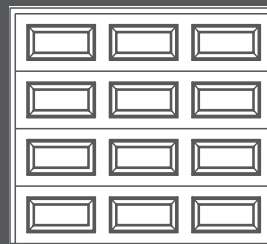

K - caisson ribs

TECHNICAL INFORMATION

UniPro garage door

Minimum garage door dimensions:

- $S_o = 1,500$ [mm] and $H_o = 1,800$ [mm] – garage doors type **N**
- $S_o = 1,500$ [mm] and $H_o = 1,900$ [mm] – garage doors type **G**, **W**, **V**
- $S_o = 2,230$ [mm] and $H_o = 1,990$ [mm] – garage doors type **K**



Available range of dimensions for tracks

Opening height ⁽¹⁾ (H_o) in [mm] up to	Opening width ⁽¹⁾ (S_o) in [mm] up to																
	2,250	2,375	2,400	2,500	2,600	2,750	3,000	3,250	3,500	3,750	4,000	4,250	4,500	4,750	5,000	5,500	6,000
2,000																	
2,100																	
2,125																	
2,200																	
2,250																	
2,375																	
2,500																	
2,625																	
2,750																	
2,875																	
3,000																	

⁽¹⁾ – Ordering dimension.

Installation dimensions

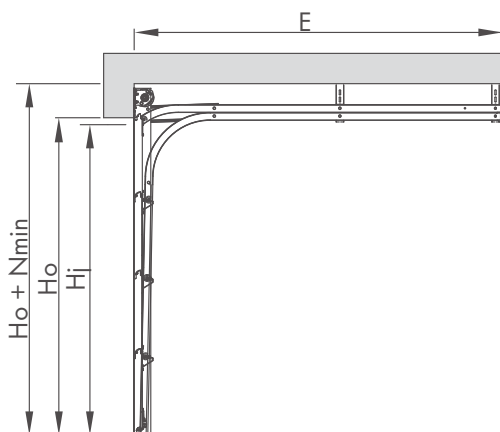

Sp		SSpN		SSpN, SSpG, SSpW, SSpK		SSpG, SSpW		SSpV
Colour/Structure		RAL 8014, RAL 9006, RAL 9016, other RAL (Woodgrain)		Golden Oak, Walnut RAL 7016, RAL 8014, RAL 9016 panel type G , W , K (Woodgrain) film coating (Smoothgrain)		Golden Oak, Walnut (Smoothgrain), Anthracite (Sandgrain) RAL 7016, RAL 9016, other RAL (Silkline)		RAL 9006, RAL 7016, other RAL (silkline)
Dimensions		standard	special	standard	special	standard	special	special
Nmin		=200[mm] for $H_o = 2,000$ [mm] $H_o = 2,100$ [mm] $H_o = 2,250$ [mm] $H_o = 2,500$ [mm] =220[mm] for $H_o = 2,125$ [mm] $H_o = 2,200$ [mm]		200 [mm]	=200 [mm] for $H_o = 2,100$ [mm] $H_o = 2,250$ [mm] =220 [mm] for $H_o = 2,125$ [mm] $H_o = 2,200$ [mm]		=200 [mm]	=200 [mm] for $H_o = 2,000$ [mm] $H_o = 2,100$ [mm] $H_o = 2,125$ [mm] $H_o = 2,250$ [mm] $H_o = 2,375$ [mm] $H_o = 2,500$ [mm] =220 [mm] for $H_o = 2,200$ [mm]
Sj		S ₀ - 40 [mm]						
Hj	Manual	H ₀ - 160 [mm]						
	Manual + catcher	H ₀ - 80 [mm]						
	With a drive unit	H ₀ - 50 [mm]						
W1, W2		110 [mm]						
E _{min}	Manual	H ₀ + 400 [mm]						
	With the MOTO drive	L _s + 300 [mm]						
	With the METRO drive	L _s + 410 [mm]						
L _s		2900 [mm] for $H_o \leq 2250$; 3500 [mm] for $H_o > 2250$ and $H_o \leq 2850$; 4500 [mm] for $H_o > 2850$						

S₀ - opening width, ordering dimension. **S_j** - clear passage width after garage door installation. **H₀** - opening height, ordering dimension. **H_j** - clear passage height after garage door installation. **N** - minimum required lintel height. **W₁** - minimum required side clearance. **W₂** - minimum required side clearance. **E** - minimum garage depth with clearance under the ceiling. **L_s** - drive rail length.

TECHNICAL INFORMATION

UniPro garage door

Minimum garage door dimensions:

- $S_o = 1,500$ [mm] and $H_o = 1,800$ [mm] – garage doors type **N**
- $S_o = 1,500$ [mm] and $H_o = 1,900$ [mm] – garage doors type **G**, **W**, **V**
- $S_o = 2,230$ [mm] and $H_o = 1,990$ [mm] – garage doors type **K**



Tracks type **St**

Available range of dimensions for tracks

Opening height ⁽¹⁾ (H_o) in [mm] up to	Opening width ⁽¹⁾ (S_o) in [mm] up to															
	2,250	2,375	2,400	2,500	2,600	2,750	3,000	3,250	3,500	3,750	4,000	4,250	4,500	4,750	5,000	5,500
2,000																
2,100																
2,125																
2,200																
2,250																
2,375																
2,500																
2,625																
2,750																
2,875																
3,000																

⁽¹⁾ – Ordering dimension.

Installation dimensions

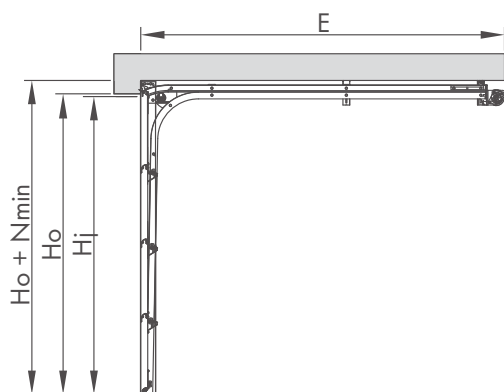

		SStN, SStG, SStW, SStK		SStV
Colour/Structure		all available colour and structure combinations		RAL 9006, RAL 7016, other RAL (silklime)
Dimensions		standard	special	special
N _{min}	Manual	100 [mm]		
	With a drive unit	140 [mm]		
S _j		S _o - 40 [mm]		
H _j	Manual	H _o - 160 [mm]		
	Manual + catcher	H _o - 90 [mm]		
	With a drive unit	H _o - 90 [mm]		
W ₁ , W ₂		110 [mm]		
E _{min}	Manual	H _o + 750 [mm]		
	With the MOTO drive	L _s + 300 [mm]		
	With the METRO drive	L _s + 410 [mm]		
L _s		2900 [mm] for H _o ≤ 2250; 3500 [mm] for H _o > 2250 and H _o ≤ 2850; 4500 [mm] for H _o > 2850		

S_o – opening width, ordering dimension. S_j – clear passage width after garage door installation. **H_o – opening height, ordering dimension.** H_j – clear passage height after garage door installation.
N – minimum required lintel height. W₁ – minimum required side clearance. W₂ – minimum required side clearance. E – minimum garage depth with clearance under the ceiling. L_s – drive rail length.

TECHNICAL INFORMATION

UniPro garage door

Minimum garage door dimensions:

- $S_o = 1,500$ [mm] and $H_o = 1,800$ [mm] – garage doors type **N**
- $S_o = 1,500$ [mm] and $H_o = 1,900$ [mm] – garage doors type **G**, **W**, **V**
- $S_o = 2,230$ [mm] and $H_o = 1,990$ [mm] – garage doors type **K**







Available range of dimensions for tracks

Opening height ⁽¹⁾ (H_o) in [mm] up to	Opening width ⁽¹⁾ (S_o) in [mm] up to																
	2,250	2,375	2,400	2,500	2,600	2,750	3,000	3,250	3,500	3,750	4,000	4,250	4,500	4,750	5,000	5,500	6,000
2,000																	
2,100																	
2,125																	
2,200																	
2,250																	
2,375																	
2,500																	
2,625																	
2,750																	
2,875																	
3,000																	

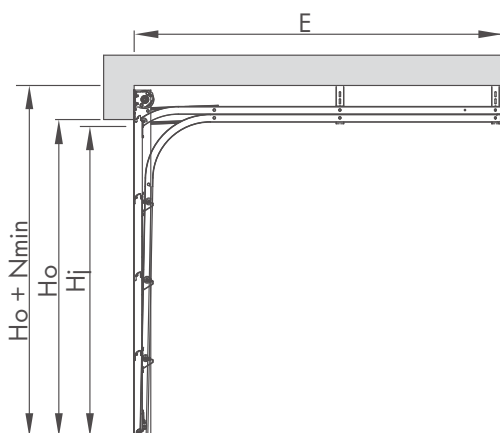
⁽¹⁾ – Ordering dimension.

Installation dimensions



		SSJN		SSJN, SSJG, SSJW, SSJK		SSJG, SSJW		
Colour/Structure		RAL 8014, RAL 9006, RAL 9016, other RAL (Woodgrain)		Golden Oak, Walnut RAL 7016, RAL 8014, RAL 9016 panel type    (Wood-grain) film coating (Smoothgrain)		Golden Oak, Walnut (Smooth-grain), Anthracite (Sandgrain) RAL 7016, RAL 9016, other RAL (Silkline)		
Dimensions		standard	special	standard	special	standard	special	
Nmin		=400 [mm] for $H_o = 2,000$ [mm] $H_o = 2,100$ [mm] $H_o = 2,250$ [mm] $H_o = 2,500$ [mm] =420 [mm] for $H_o = 2,125$ [mm] $H_o = 2,200$ [mm]		=400 [mm]	=400 [mm] for $H_o = 2,100$ [mm] $H_o = 2,250$ [mm] =420 [mm] for $H_o = 2,125$ [mm] $H_o = 2,200$ [mm]	=400 [mm]	=400 [mm] for $H_o = 2,000$ [mm] $H_o = 2,100$ [mm] $H_o = 2,125$ [mm] $H_o = 2,250$ [mm] $H_o = 2,375$ [mm] $H_o = 2,500$ [mm] =420 [mm] for $H_o = 2,200$ [mm]	=400 [mm]
Sj		S ₀ - 40 [mm]						
Hj	Manual	H _j = H _o - 20 [mm]						
	Manual + catcher							
	With a drive unit							
W1, W2		110 [mm]						
Emin	Manual	H _o + 400 [mm]						
	With the MOTO drive	L _s + 300 [mm]						
	With the METRO drive	L _s + 410 [mm]						
L _s		2900 [mm] for H _o ≤ 2250; 3500 [mm] for H _o > 2250 and H _o ≤ 2850; 4500 [mm] for H _o > 2850						

S₀ – opening width, ordering dimension. **S_j** – clear passage width after garage door installation. **H_o** – opening height, ordering dimension. **H_j** – clear passage height after garage door installation. **N** – minimum required lintel height. **W₁** – minimum required side clearance. **W₂** – minimum required side clearance. **E** – minimum garage depth with clearance under the ceiling. **L_s** – drive rail length.

TECHNICAL INFORMATION

UniPro garage door

Minimum garage door dimensions:

- $S_o = 1,500$ [mm] and $H_o = 1,800$ [mm] – garage doors type **N**
- $S_o = 1,500$ [mm] and $H_o = 1,900$ [mm] – garage doors type **G**, **W**, **V**
- $S_o = 2,230$ [mm] and $H_o = 1,990$ [mm] – garage doors type **K**



Available range of dimensions for tracks

Opening height ⁽¹⁾ (H_o) in [mm] up to	Opening width ⁽¹⁾ (S_o) in [mm] up to														
	2,250	2,375	2,400	2,500	2,600	2,750	3,000	3,250	3,500	3,750	4,000	4,250	4,500	4,750	5,000
2,000															
2,100															
2,125															
2,200															
2,250															
2,375															
2,500															
2,625															
2,750															
2,875															
3,000															

⁽¹⁾ – Ordering dimension.

Installation dimensions

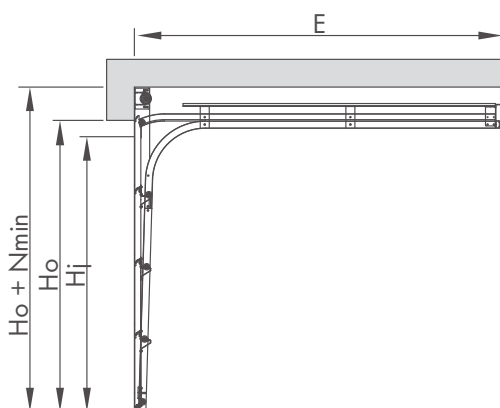

Colour/Structure	SNN		SNN, SNG, SNW, SNK		SNG, SNW	
	standard	special	standard	special	standard	special
Colour/Structure	RAL 8014, RAL 9006, RAL 9016, other RAL (Woodgrain)		Golden Oak, Walnut RAL 7016, RAL 8014, RAL 9016 panel type G , W , K (Wood-grain) film coating (Smoothgrain)		Golden Oak, Walnut (Smoothgrain), Anthracite (Sandgrain) RAL 7016, RAL 9016, other RAL (Silkline)	
Dimensions	standard	special	standard	special	standard	special
Nmin	=220 [mm] for Ho = 2,100 [mm] Ho = 2,125 [mm] Ho = 2,200 [mm] Ho = 2,250 [mm] =250 [mm] for Ho = 2,000 [mm] Ho = 2,500 [mm]	=220 [mm]	=200 [mm] for Ho = 2,100 [mm] Ho = 2,250 [mm] =240 [mm] for Ho = 2,125 [mm] Ho = 2,200 [mm]	=220 [mm]	=220 [mm] for Ho = 2,000 [mm] Ho = 2,100 [mm] Ho = 2,125 [mm] Ho = 2,250 [mm] Ho = 2,375 [mm] Ho = 2,500 [mm] =240 [mm] for Ho = 2,200 [mm]	=220 [mm]
Sj	So - 40 [mm]					
Hj	Manual		Ho - 130 [mm]			
	Manual + catcher		Ho - 80 [mm]			
	With a drive unit					
W1, W2	110 [mm]					
Emin	Manual		Ho + 800 [mm]			
	With the MOTO drive		Ls + 300 [mm]			
	With the METRO drive		Ls + 410 [mm]			
Ls	2900 [mm] for Ho ≤ 2250; 3500 [mm] for Ho > 2250 and Ho ≤ 2850; 4500 [mm] for Ho > 2850					

So – opening width, ordering dimension. Sj – clear passage width after garage door installation. Ho – opening height, ordering dimension. Hj – clear passage height after garage door installation. N – minimum required lintel height. W1 – minimum required side clearance. W2 – minimum required side clearance. E – minimum garage depth with clearance under the ceiling. Ls – drive rail length.

TECHNICAL INFORMATION

UniPro garage door

Minimum garage door dimensions:

- $S_o = 1,500$ [mm] and $H_o = 1,800$ [mm] – garage doors type **N**
- $S_o = 1,500$ [mm] and $H_o = 1,900$ [mm] – garage doors type **G**, **W**, **V**
- $S_o = 2,230$ [mm] and $H_o = 1,990$ [mm] – garage doors type **K**



Tracks type **StA**

Available range of dimensions for tracks

Opening height ⁽¹⁾ (H_o) in [mm] up to	Opening width ⁽¹⁾ (S_o) in [mm] up to															
	2,250	2,375	2,400	2,500	2,600	2,750	3,000	3,250	3,500	3,750	4,000	4,250	4,500	4,750	5,000	5,500
2,000																
2,100																
2,125																
2,200																
2,250																
2,375																
2,500																
2,625																

⁽¹⁾ – Ordering dimension.

Installation dimensions

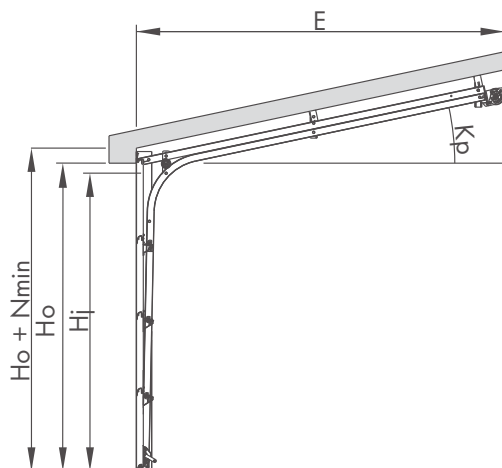

SfA	N _{min}		H _j			S _j	W ₁ , W ₂	
	K _p	manual	automatic	manual	manual + catcher			automatic
	degrees [°]	[mm]	[mm]	[mm]	[mm]	[mm]	[mm]	
	2	140	170	H _o - 100	H _o - 80	H _o - 70	S _o - 40	110
	3	135	165	H _o - 110	H _o - 90	H _o - 70		
	4	130	160	H _o - 120	H _o - 90	H _o - 70		
	5	120	150	H _o - 130	H _o - 90	H _o - 70		
	6	110	140	H _o - 140	H _o - 90	H _o - 70		
	7	110	140	H _o - 140	H _o - 90	H _o - 70		
	8	100	130	H _o - 140	-	H _o - 70		
	9	100	120	H _o - 140	-	H _o - 70		
	10	100	110	H _o - 140	-	H _o - 70		
	11 to 20	100	100	H _o - 140	-	H _o - 60		

Minimum garage depth

E _{min}
Automatic: $E_{min} = \cos(K_p) \times E_{min}'$
Manual: $E_{min} = \cos(K_p) \times (H_o + 30 + 450)$
H _o - opening height
E _{min'} - value from the table, depending on the automatic operating unit and H _o
K _p - inclination angle of the ceiling in relation to the floor

Drive unit	E _{min'}	Height H _o
MOTO	3,200	0 - 2,250
	3,800	2,251 - 3,000
	4,800	2,851 - 3,150
METRO	3,310	0 - 2,250
	3,910	2,251 - 2,850
	4,910	2,851 - 3,150

S_o - opening width, ordering dimension. **S_j** - clear passage width after garage door installation. **H_o** - opening height, ordering dimension. **H_j** - clear passage height after garage door installation. **N** - minimum required lintel height. **W₁** - minimum required side clearance. **W₂** - minimum required side clearance. **E** - minimum garage depth with clearance under the ceiling. **L_s** - drive rail length.

TECHNICAL INFORMATION

UniPro garage door

Minimum garage door dimensions:

- $S_o = 1,500$ [mm] and $H_o = 1,800$ [mm] – garage doors type **N**
- $S_o = 1,500$ [mm] and $H_o = 1,900$ [mm] – garage doors type **G**, **W**, **V**
- $S_o = 2,230$ [mm] and $H_o = 1,990$ [mm] – garage doors type **K**



Tracks type **SpA**

Available range of dimensions for tracks

Opening height ⁽¹⁾ (H_o) in [mm] up to	Opening width ⁽¹⁾ (S_o) in [mm] up to														
	2,250	2,375	2,400	2,500	2,600	2,750	3,000	3,250	3,500	3,750	4,000	4,250	4,500	4,750	5,000
2,000															
2,100															
2,125															
2,200															
2,250															
2,375															
2,500															
2,625															

⁽¹⁾ – Ordering dimension.

Installation dimensions

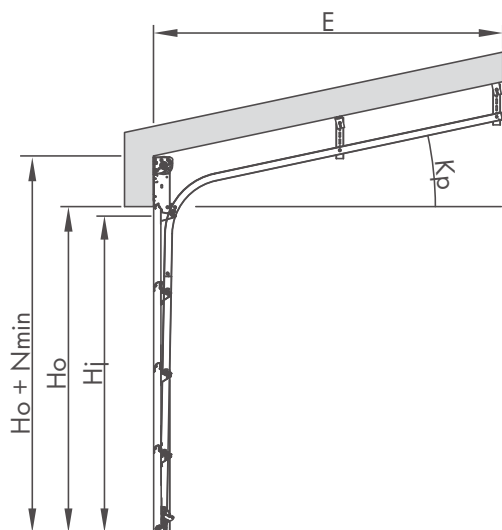

SpA	N_{min}		H_j		S_j	W_1, W_2
	K_p	manual	automatic	manual		
	degrees [°]	[mm]	[mm]	[mm]	[mm]	[mm]
	2 to 3	360	390	$H_o - 50$	$H_o - 20$	110
	4	350	380	$H_o - 50$	$H_o - 20$	
	5 to 6	350	370	$H_o - 50$	$H_o - 20$	
	7	350	360	$H_o - 50$	$H_o - 20$	
	8 to 20	350	350	$H_o - 50$	$H_o - 20$	

Minimum garage depth

E_{min}
Automatic: $E_{min} = \cos(K_p) \times E_{min}'$
Manual: $E_{min} = \cos(K_p) \times (H_o + 30 + 450)$
H_o - opening height
E_{min}' - value from the table, depending on the automatic operating unit and H_o
K_p - inclination angle of the ceiling in relation to the floor

Drive unit	E_{min}'	Height H_o
MOTO	3,200	0 - 2,250
	3,800	2,251 - 3,000
	4,800	2,851 - 3,150
METRO	3,310	0 - 2,250
	3,910	2,251 - 2,850
	4,910	2,851 - 3,150

S_o - opening width, ordering dimension. S_j - clear passage width after garage door installation **H_o - opening height, ordering dimension.** H_j - clear passage height after garage door installation.
 N - minimum required lintel height. W_1 - minimum required side clearance. W_2 - minimum required side clearance. E - minimum garage depth with clearance under the ceiling. L_s - drive rail length.

TECHNICAL INFORMATION

UniPro Nano80 garage door

Minimum garage door dimensions:

- $S_o = 1,500$ [mm] and $H_o = 1,955$ [mm] – garage doors type **G**, **W**, **V**, **N**
- $S_o = 2,230$ [mm] and $H_o = 2,040$ [mm] – garage doors type **K**



Tracks type HL

Available range of dimensions for tracks

Opening height ⁽¹⁾ (H_o) in [mm] up to	Opening width ⁽¹⁾ (S_o) in [mm] up to															
	2,250	2,375	2,400	2,500	2,600	2,750	3,000	3,250	3,500	3,750	4,000	4,250	4,500	4,750	5,000	5,500
2,000																
2,100																
2,125																
2,200																
2,250																
2,375																
2,500																
2,625																
2,750																
2,875																
3,000																

⁽¹⁾ – Ordering dimension.

Installation dimensions

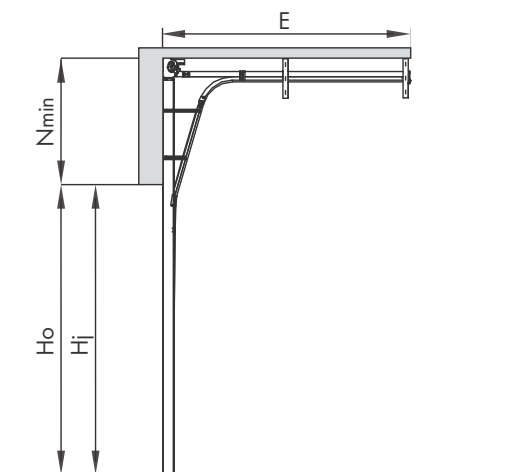

HL		SHLN, SHLG, SHLW, SHLK	
Colour/Structure		all available colour and structure combinations	
Dimensions		standard	special
Nmin	Manual	400 < N ≤ 1300	
	With a drive unit		
Sj		S ₀ - 40 [mm]	
Hj	Manual	H ₀ - 20 [mm]	
	With a drive unit		
W1, W2		110 [mm]	
Emin	Manual	H ₀ - 0,8 x N+645 [mm]	
	With the MOTO drive	3200 [mm] for H ₀ ≤ 2080; 3800 [mm] for 2080 < H ₀ ≤ 2680; 4800 [mm] for H ₀ > 2680	
	With the METRO drive	3310 [mm] for H ₀ ≤ 2080; 3910 [mm] for 2080 < H ₀ ≤ 2680; 4910 [mm] for H ₀ > 2680	

S₀ – opening width, ordering dimension. **S_j** – clear passage width after garage door installation. **H₀** – opening height, ordering dimension. **H_j** – clear passage height after garage door installation.
N – minimum required lintel height. **W₁** – minimum required side clearance. **W₂** – minimum required side clearance. **E** – minimum garage depth with clearance under the ceiling. **L_s** – drive rail length.

TECHNICAL INFORMATION

UniPro garage door

Minimum garage door dimensions:

- $S_o = 1,500$ [mm] and $H_o = 1,800$ [mm] – garage doors type **N**
- $S_o = 1,500$ [mm] and $H_o = 1,900$ [mm] – garage doors type **G**, **W**, **V**
- $S_o = 2,230$ [mm] and $H_o = 1,990$ [mm] – garage doors type **K**
- $S_o \leq 1,750$ [mm] and $H_{o \max} = 2,500$ [mm], $1,750$ [mm] $< S_o \leq 2,000$ [mm] $H_{o \max} = 2,750$ [mm]





Available range of dimensions for tracks

Opening height ⁽¹⁾ (H_o) in [mm] up to	Opening width ⁽¹⁾ (S_o) in [mm] up to												
	2,250	2,375	2,400	2,500	2,600	2,750	3,000	3,250	3,500	3,750	4,000	4,250	4,500
2,000													
2,100													
2,125													
2,200													
2,250													
2,375													
2,500													
2,625													
2,750													
2,875													
3,000													

⁽¹⁾ – Ordering dimension.

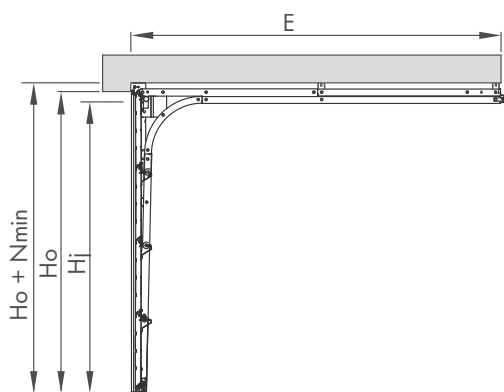
Installation dimensions



		SNPN, SNPG, SNPW, SNPK		SNPV
Colour/Structure		all available colour and structure combinations		RAL 9006, RAL 7016, other RAL (silklime)
Dimension		standard	special	special
Nmin	Manual	90 [mm]		
	With the MOTO drive	100 [mm]		
	With the METRO drive	100 [mm]		
Sj		$S_o - 40$ [mm]		
Hj	Manual + catcher (standard)	$H_o - 60$ [mm]		
	With a drive unit	$H_o - 60$ [mm]		
W1, W2		100 [mm]		
Emin	Manual	$H_o + 600$ [mm]		
	With the MOTO drive	$L_s + 300$ [mm]		
	With the METRO drive	$L_s + 410$ [mm]		
Ls		2900 [mm] for $H_o \leq 2250$; 3500 [mm] for $H_o > 2250$ and $H_o \leq 2850$; 4500 [mm] for $H_o > 2850$		

So – opening width, ordering dimension. **Sj** – clear passage width after garage door installation. **Ho** – opening height, ordering dimension. **Hj** – clear passage height after garage door installation. **N** – minimum required lintel height. **W1** – minimum required side clearance. **W2** – minimum required side clearance. **E** – minimum garage depth with clearance under the ceiling. **Ls** – drive rail length.

TECHNICAL INFORMATION

UniPro Nano80 garage door

Minimum garage door dimensions:

- $S_o = 1,500$ [mm] and $H_o = 1,955$ [mm] - garage doors type **G**, **W**, **V**, **N**
- $S_o = 2,230$ [mm] and $H_o = 2,040$ [mm] - garage doors type **K**



Tracks type **Nano80**

Available range of dimensions for tracks

Opening height ⁽¹⁾ (H_o) in [mm] up to	Opening width ⁽¹⁾ (S_o) in [mm] up to															
	2,250	2,375	2,400	2,500	2,600	2,750	3,000	3,250	3,500	3,750	4,000	4,250	4,500	4,750	5,000	5,500
2,000																
2,100																
2,125																
2,200																
2,250																
2,375																
2,500																
2,625																
2,750																
2,875																
3,000																

⁽¹⁾ - Ordering dimension.

Installation dimensions

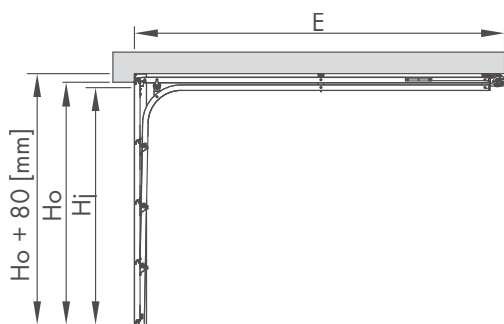

Nano80		SStN, SStG, SStW, SStK	
Colour/Structure		all available colour and structure combinations	
Dimensions		standard	special
N _{min}	With a drive unit	80 [mm]	
S _j		S _O - 40 [mm]	
H _j	With the MOTO drive	H _O - 80 [mm]	
	With the METRO drive	H _O - 80 [mm]	
W ₁ , W ₂		110 [mm]	
E _{min}	With the MOTO drive	L _S + 600 [mm]	
	With the METRO drive	L _S + 600 [mm]	
L _S		2900 [mm] for H _O ≤ 2250; 3500 [mm] for H _O > 2250 and H _O ≤ 2850; 4500 [mm] for H _O > 2850	

S_o - opening width, ordering dimension. S_j - clear passage width after garage door installation **H_o - opening height, ordering dimension.** H_j - clear passage height after garage door installation.
 N - minimum required lintel height. W₁ - minimum required side clearance. W₂ - minimum required side clearance. E - minimum garage depth with clearance under the ceiling. L_S - drive rail length.

TECHNICAL INFORMATION

UniPro RenoSystem garage door

Minimum garage door dimensions:

- $S_o = 1,500$ [mm] and $H_o = 1,800$ [mm] - garage doors type **N**
- $S_o = 1,500$ [mm] and $H_o = 1,900$ [mm] - garage doors type **G**, **W**, **V**



Tracks type **St**

Available range of dimensions for tracks

Opening height (H_o) in [mm] up to	Opening width (S_o) in [mm] up to														
	2,250	2,375	2,400	2,500	2,600	2,750	3,000	3,250	3,500	3,750	4,000	4,250	4,500	4,750	5,000
2,000															
2,100															
2,125															
2,200															
2,250															
2,375															
2,500															
2,625															
2,750															
2,875															

Installation dimensions

Installation behind the opening – fascia panel behind the opening

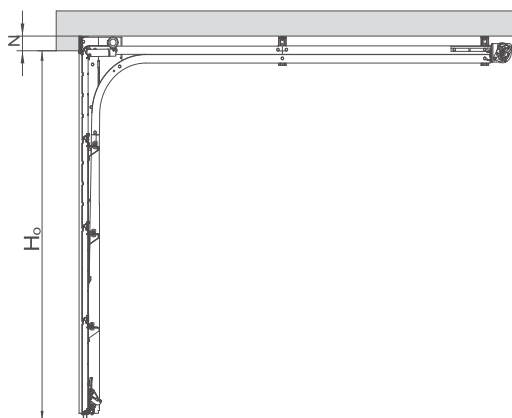

Installation in the opening – fascia panel in the opening

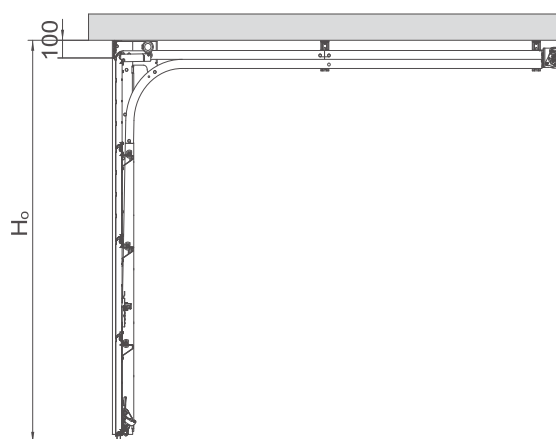

Installation in the opening – fascia panel in front of the opening

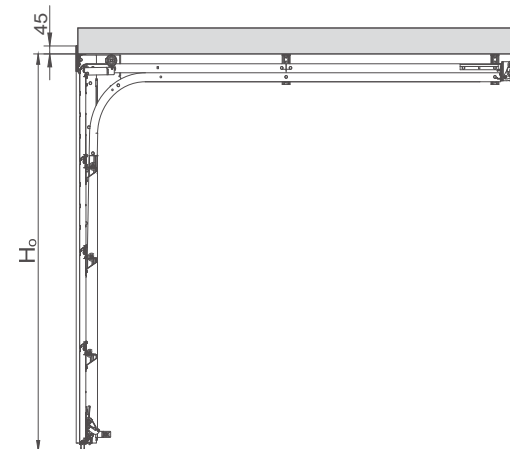

		Installation behind the opening	Installation in the opening
Sj		$So - 240 \text{ [mm]} + W_1 + W_2$	$So - 240 \text{ [mm]}$
Hj	manual	$H_o - 210 \text{ [mm]} + N$	$H_o - 210 \text{ [mm]}$
	manual + catcher ⁽¹⁾	$H_o - 150 \text{ [mm]} + N$	$H_o - 150 \text{ [mm]}$
	with a drive unit ⁽¹⁾	$H_o - 160 \text{ [mm]} + N$	$H_o - 160 \text{ [mm]}$
N_{min}		0 [mm]	0 [mm]
W_{1min}, W_{2min}		0 [mm]	0 [mm]

So – opening width, ordering dimension. Sj – clear passage width after garage door installation. **Ho – opening height, ordering dimension.** Hj – clear passage height after garage door installation.
N – minimum required lintel height. W₁ – minimum required side clearance. W₂ – minimum required side clearance. E – minimum garage depth with clearance under the ceiling. Ls – drive rail length.

⁽¹⁾ – When a lock is fitted in the garage door with a safety brake Hj = Ho-190 [mm] + N

TECHNICAL INFORMATION

UniTherm garage door

Minimum garage door dimensions: $S_o = 2,000$ [mm] and $H_o = 1,800$ [mm]



Tracks type **Sp**

Available range of dimensions for tracks

Opening height ⁽¹⁾ (H_o) in [mm] up to	Opening width ⁽¹⁾ (S_o) in [mm] up to																
	2,250	2,375	2,400	2,500	2,600	2,750	3,000	3,250	3,500	3,750	4,000	4,250	4,500	4,750	5,000	5,500	6,000
2,000																	
2,100																	
2,125																	
2,200																	
2,250																	
2,375																	
2,500																	
2,625																	
2,750																	
2,875																	
3,000																	

⁽¹⁾ – Ordering dimension.

Installation dimensions

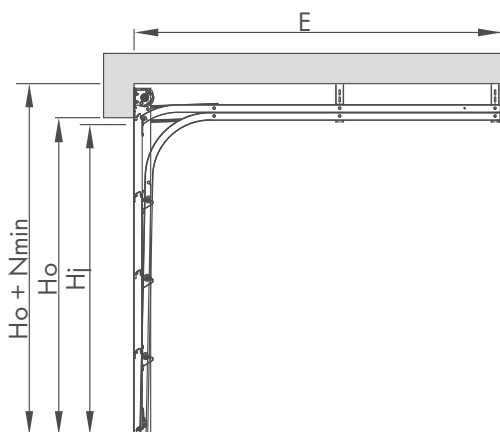

UniTherm		SSp
Sj		$S_o - 40$ [mm]
Hj	Manual	$H_o - 280$ [mm]
	Manual + catcher	$H_o - 140$ [mm]
	With the MOTO drive	$H_o - 100$ [mm]
	With the METRO drive	$H_o - 100$ [mm]
W1min, W2min		110 [mm]
Emin	Manual	$H_o + 400$ [mm]
	With the MOTO drive	$L_s + 300$
	With the METRO drive	$L_s + 410$
Ls	2900 [mm] for $H_o \leq 2250$; 3500 [mm] for $H_o > 2250$ and $H_o \leq 2850$; 4500 [mm] for $H_o > 2850$	

Minimum lintel height

Standard garage door height [mm]	Nmin [mm]	
	SSp	
	Manual	Automatic
2,000	200	200
2,100	200	200
2,125	200	200
2,200	220	220
2,250	200	200
2,375	200	200
2,500	200	200
Custom garage door height	200	200

So – opening width, ordering dimension. **Sj** – clear passage width after garage door installation. **Ho** – opening height, ordering dimension. **Hj** – clear passage height after garage door installation. **N** – minimum required lintel height. **W1** – minimum required side clearance. **W2** – minimum required side clearance. **E** – minimum garage depth with clearance under the ceiling. **Ls** – drive rail length.

TECHNICAL INFORMATION

UniTherm garage door

Minimum garage door dimensions: So = 2,000 [mm] and Ho = 1,800 [mm]



Available range of dimensions for tracks

Opening height ⁽¹⁾ (Ho) in [mm] up to	Opening width ⁽¹⁾ (So) in [mm] up to															
	2,250	2,375	2,400	2,500	2,600	2,750	3,000	3,250	3,500	3,750	4,000	4,250	4,500	4,750	5,000	5,500
2,000																
2,100																
2,125																
2,200																
2,250																
2,375																
2,500																
2,625																
2,750																
2,875																
3,000																

⁽¹⁾ - Ordering dimension.

Installation dimensions

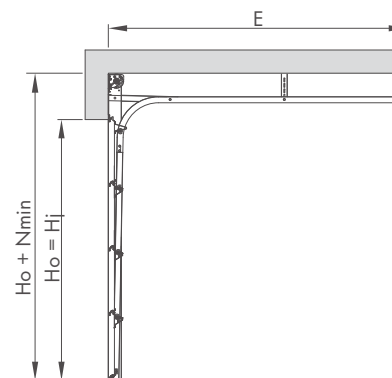
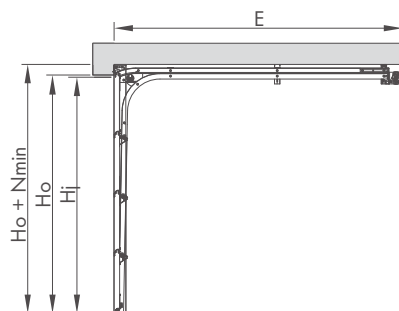

UniTherm		SSt	SSj
Sj		$S_0 - 40$ [mm]	$S_0 - 40$ [mm]
Hj	Manual	$H_0 - 190$ [mm]	-
	Manual + catcher	$H_0 - 140$ [mm]	H_0
	With the MOTO drive	$H_0 - 140$ [mm]	H_0
	With the METRO drive	$H_0 - 140$ [mm]	H_0
W1min, W2min		110 [mm]	
Emin	Manual	$H_0 + 750$ [mm]	$H_0 + 400$ [mm]
	With the MOTO drive	$L_s + 300$	
	With the METRO drive	$L_s + 410$	
Ls	2900 [mm] for $H_0 \leq 2250$; 3500 [mm] for $H_0 > 2250$ and $H_0 \leq 2850$; 4500 [mm] for $H_0 > 2850$		

Minimum lintel height

Opening garage door height [mm]	Nmin [mm]			
	SSt		SSj	
	Manual	Automatic	Manual	Automatic
2,000	105	140	400	400
2,100	105	140	400	400
2,125	105	140	400	400
2,200	115	150	410	410
2,250	105	140	400	400
2,375	105	140	400	400
2,500	105	140	400	400
Custom garage door height	105	140	400	400

So – opening width, ordering dimension. **Sj** – clear passage width after garage door installation. **Ho** – opening height, ordering dimension. **Hj** – clear passage height after garage door installation. **N** – minimum required lintel height. **W1** – minimum required side clearance. **W2** – minimum required side clearance. **E** – minimum garage depth with clearance under the ceiling. **Ls** – drive rail length.

TECHNICAL INFORMATION

PRIME garage door

Minimum garage door dimensions: $S_o = 2,000$ [mm] and $H_o = 1900$ [mm]



Available range of dimensions for tracks

Opening height ⁽¹⁾ (H_o) in [mm] up to	Opening width ⁽¹⁾ (S_o) in [mm] up to																
	2,250	2,375	2,400	2,500	2,600	2,750	3,000	3,250	3,500	3,750	4,000	4,250	4,500	4,750	5,000	5,500	6,000
2,000																	
2,100																	
2,125																	
2,200																	
2,250																	
2,375																	
2,500																	
2,625																	
2,750																	
2,875																	
3,000																	

Installation dimensions

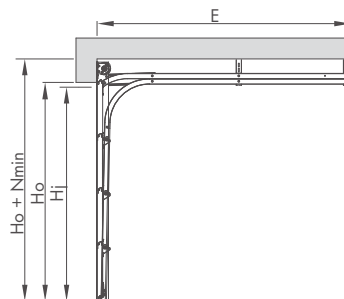

PRIME		
Sj		$S_o - 40$ [mm]
Hj		$H_o - 100$ [mm]
Nmin		200 [mm] ⁽²⁾
W1min, W2min		160 [mm]
Emin	METRO	$L_s + 410$ [mm]
Ls	METRO	2900 [mm] or 3500 [mm]

So – opening width, ordering dimension. **Sj** – clear passage width after garage door installation. **Ho** – opening height, ordering dimension. **Hj** – clear passage height after garage door installation. **N** – minimum required lintel height. **W1** – minimum required side clearance. **W2** – minimum required side clearance. **E** – minimum garage depth with clearance under the ceiling. **Ls** – drive rail length.
⁽¹⁾ – Ordering dimension. ⁽²⁾ – For garage door height 2,200 [mm] Nmin is 220 [mm].

Let us inspire you
in your search for new solutions!



Apart from sectional garage doors, WIŚNIEWSKI also offers other garage door solutions: roller, up and over, and double-leaf garage doors.

This diversity is our response to the requirements of our customers. Let us surprise you with the multitude of options.

WIŚNIEWSKI. Gates, windows, doors, fences.

It's great when everything **goes** **together perfectly...**

because harmony is the highest form of beauty. Choose your **garage door, windows,** and **shutters,** as well as **doors** and **fence** in the Home Inclusive™ system, which will create a matching set in terms of design and colour. Highlight this harmony with the smartCONNECTED smart control function and meet perfection that will never go out of fashion. A matching set of joinery and fence? From a single manufacturer in uniform design – because it is great when all the elements harmonize with your dreams, your home, and one another.



HI MARINA HORIZO

LET US INSPIRE YOU WITH OUR NEW HOME INCLUSIVE COLLECTION FEATURING 16 UNIQ

HI EARTH





HI QUARTZ GREY



ON

HI ANTHRACITE



HI DEEP GREEN



UE COLOURS!

HI STONE



HI STEEL



HI RUBY





WIŚNIEWSKI

GATES | WINDOWS | DOORS | FENCES



DISCOVER
MORE...



www.wisniowski.eu

The products shown in the photographic material often feature special equipment and do not always correspond to their standard versions • This brochure does not constitute an offer within the meaning of the Polish Civil Code.
• The manufacturer reserves the right to introduce changes without notice. • NOTE: The colours shown in this brochure are for reference only • All rights reserved • Copying and use, in part or in full, is prohibited without the consent of WIŚNIEWSKI Sp. z o.o. S.K.A. • 12/21/EN